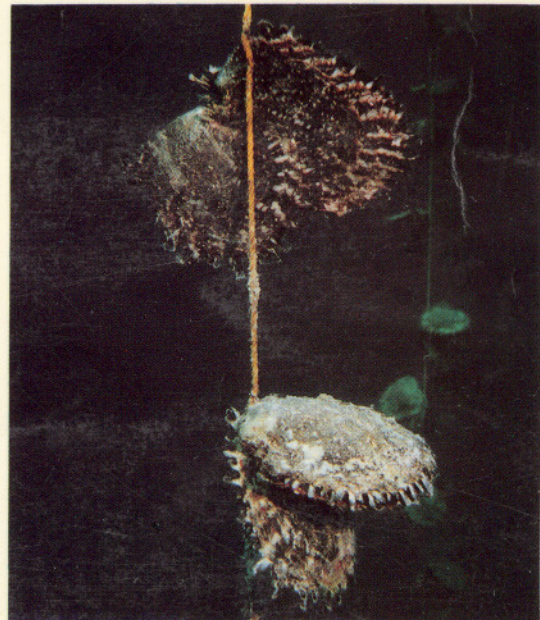


SH  
207  
SR76  
# 21  
c.1

# The Biology and Culture of Pearl Oysters (Bivalvia: Pteriidae)

M.H. GERVIS and N.A. SIMS



OVERSEAS DEVELOPMENT ADMINISTRATION (ODA)  
OF THE UNITED KINGDOM  
LONDON, ENGLAND



INTERNATIONAL CENTER FOR LIVING AQUATIC  
RESOURCES MANAGEMENT  
MANILA, PHILIPPINES



Library



1000001855

*in N<sup>o</sup> 2  
my  
internal  
file*

# The Biology and Culture of Pearl Oysters (Bivalvia: Pteriidae)

M.H. GERVIS and N.A. SIMS

1992



OVERSEAS DEVELOPMENT ADMINISTRATION (ODA)  
OF THE UNITED KINGDOM  
LONDON, ENGLAND



INTERNATIONAL CENTER FOR LIVING AQUATIC  
RESOURCES MANAGEMENT  
MANILA, PHILIPPINES

**The Biology and Culture  
of Pearl Oysters  
(Bivalvia: Pteriidae)**

SH  
207  
SP 3/8  
#6  
2.1  
NOV 2 1992

M.H. GERVIS AND N.A. SIMS

1992

Printed in Manila, Philippines

Published by the Overseas Development Administration  
94 Victoria Street, London SW1E 5JL, United Kingdom and  
the International Center for Living Aquatic Resources  
Management, MC P.O. Box 1501, Makati, Metro Manila,  
Philippines.

ICLARM's Technical Series were developed in response to the lack of existing publishing outlets for longer papers on tropical fisheries research.

The ICLARM Studies and Reviews series consists of concise documents providing thorough coverage of topics of interest to the Center, which are undertaken by staff or by external specialists on commission.

Essentially, all documents in the series are carefully peer reviewed externally and internally. A number have been rejected. Those published are thus primary literature. Between 1,000 and 2,000 copies of each title are disseminated - sold or provided in exchange or free of charge.

Gervis, M.H. and N.A. Sims. 1992. The biology and culture of pearl oysters (Bivalvia: Pteriidae). ICLARM Stud. Rev. 21, 49 p.

ISSN 0115-4389  
ISBN 971-8709-27-4

Cover: Top: Ago Bay, Japan - Home of pearl culture. (Photo by M. Gervis). Bottom, left: *P. margaritifera* being harvested from spat collectors in the Cook Islands. (Photo by N. Sims). Bottom, right: *P. margaritifera* suspended on a longline by the ear hanging technique. (Photo by N. Sims).

ICLARM Contribution No. 837

9917

# CONTENTS

<b>ABSTRACT</b> .....	v
<b>INTRODUCTION</b>	
History of Pearls and Pearl Culture .....	1
<b>TAXONOMY AND DISTRIBUTION</b>	
Taxonomy .....	3
Species Descriptions .....	4
<i>Pinctada maxima</i> .....	4
<i>Pinctada margaritifera</i> .....	5
<i>Pinctada fucata</i> .....	5
<i>Pteria penguin</i> .....	5
Distribution .....	5
Species Introductions .....	8
<b>ECOLOGY AND BIOLOGY</b>	
Anatomy .....	9
<i>Shell</i> .....	9
<i>Foot and byssal gland</i> .....	10
Environmental Factors .....	10
<i>Temperature</i> .....	10
<i>Depth</i> .....	11
<i>Salinity</i> .....	11
<i>Substrate and silt load</i> .....	12
<i>Currents</i> .....	12
<i>Pollution</i> .....	12
Food and Feeding .....	13
Reproduction .....	13
<i>Sexuality</i> .....	13
<i>Maturity</i> .....	13
<i>Gonad development</i> .....	14
<i>Spawning seasonality</i> .....	15
<i>Spawning process</i> .....	15
<i>Larval development</i> .....	15
Growth .....	16
<i>Shell dimensions</i> .....	17
Dorsoventral measurement (DVM) .....	17
Anteroposterior measurement (APM) .....	17
Hinge length .....	17
Heel depth .....	18
Thickness and hinge width .....	18
<i>Weight</i> .....	18
<i>Morphometrics</i> .....	18

<i>Growth rates</i> .....	18
<i>Factors affecting growth</i> .....	19
Mortality .....	19
<i>Predation</i> .....	19
<i>Fouling and boring</i> .....	20
<i>Parasites and pathogens</i> .....	21
<b>CULTURE OF PEARL OYSTERS</b>	
Hatchery Culture .....	22
<i>Spawning</i> .....	22
<i>Larval rearing</i> .....	23
<i>Larval feeding</i> .....	23
Aspects of Pearl Oyster Culture (Photo Section) .....	24-25
<i>Settlement</i> .....	26
Genetics and Hatchery Production .....	27
Spat Collection .....	27
Nursery Rearing .....	29
Ongrowing .....	30
<i>Rafts</i> .....	31
<i>Longlines and fencelines</i> .....	32
<i>Trestles</i> .....	34
Fouling Control .....	34
Pearl Culture .....	34
<i>Preoperative phase</i> .....	35
<i>Spherical pearl implant operation</i> .....	35
<i>Pearl formation</i> .....	37
<i>Postoperative care</i> .....	37
<i>Pearl culture period</i> .....	37
<i>Harvesting</i> .....	37
<i>Half pearl production</i> .....	38
<b>MARKETING AND ECONOMICS</b> .....	39
<b>CONCLUSIONS</b> .....	41
<b>ACKNOWLEDGMENTS</b> .....	41
<b>REFERENCES</b> .....	42

# The Biology and Culture of Pearl Oysters (Bivalvia: Pteriidae)

**M.H. GERVIS**

*ICLARM*

*Coastal Aquaculture Centre*

*P.O. Box 438*

*Honiara, Solomon Islands*

**N.A. SIMS**

*73-4369 Old Government Mauka Rd.*

*Kailua-Kona, Hawaii 96740*

*USA*

## ABSTRACT

Pearl oysters are farmed throughout the Indo-Pacific region, including the Red Sea. The biology and ecology of four pearl oyster species from the family Pteriidae, *Pinctada fucata*, *P. maxima*, *P. margaritifera* and *Pteria penguin*, are reviewed here. The culture techniques used for each of these species is described and the research needs, economics and marketing aspects are discussed. *P. margaritifera* and *P. maxima* culture is likely to proliferate throughout the Indo-Pacific region in the next decade and there is also good potential for developing *P. fucata* culture in India and Sri Lanka. The culture of *P. fucata martensii* in Japan faces stagnation or reduced profitability unless remedial measures are taken to improve the culture environment and the quality standards imposed on exported pearls.

## INTRODUCTION

Pearl culture presents a significant potential for economic development in coastal village communities throughout the range of the more valuable species. The industry requires minimal capital input, yet has wide ranging benefits to farmers, coastal communities and national economies. Pearls are the ideal export commodity; they are nonperishable, shipping costs are negligible, and lucrative markets are already established.

The biology of pearl oysters is poorly understood, considering the importance of pearl culture and shell fisheries. Research and development priorities in developing countries include the assessment and protection of remaining stocks, evaluation of culture potential, and definition of management strategies for disease prevention. Improvements in spat collection methods, recent hatchery culture successes, selective breeding and genetic manipulation, and advances in pearl implantation techniques all have potential applications in village-based production.

This review aims to consolidate much of the existing information on the biology and culture of pearl oysters. It is hoped that it will go some way towards helping governments and individuals assess the potential of their coastal waters for pearl oyster culture and will encourage further research and development, especially for village-based production, of these species.

### History of Pearls and Pearl Culture

The major producers of cultured pearls have traditionally been Japan and Australia. Indonesia, India, Sri Lanka, Malaysia, Thailand, Mexico, Sudan, the Philippines, French Polynesia, Burma, the Cook Islands, Korea, Taiwan and China also have industries based on the culture of pearl oysters.

Pearls and pearl shell have long been highly prized. The shell has been used for a wide range of decorative and practical purposes from Fijian breast plates to fishing lures, buttons and inlay

material. Pearls themselves have always been objects of great value and have symbolized love, chastity, purity or feminine charms in various societies. Good quality natural pearls are rare and therefore extremely valuable. The history, distribution and importance of the pearl as a gem is described in Kunz and Stevenson (1908), George (1978) and Ward (1985).

There has been much debate as to the producer of the first cultured pearls. The Chinese were producing pearl images of Buddha by the 12th century by attaching carved images of the Buddha onto the valves of freshwater mussels in the same manner in which half pearls are produced today. Carl Von Linné, the famous naturalist, claimed to have produced spherical pearls from a freshwater mussel in 1761 (George 1978) but this was treated with scepticism. George (1978), believed that W. Saville-Kent produced the first spherical pearls in the 1890s from *P. maxima*. Patents were first filed independently for the procedure by two Japanese, Dr. Nishikawa and T. Mise who are believed to have had knowledge of the techniques of Saville-Kent. A joint patent was awarded after a series of court battles. K. Mikimoto had received a patent for the production of half pearls in 1896 and quickly dominated the round pearl culture industry. By his showmanship, marketing and extravagant pearl creations, Mikimoto brought acceptance to cultured pearls.

Although pearl production has expanded throughout much of the Indo-Pacific, the Japanese remain the dominant force in the industry. This was initially enforced through the Japanese government's "diamond policy" written in 1953 which specified that:

- a) the pearl cultivating techniques shall remain secret to all but the Japanese;
- b) the production objectives shall be controlled and regulated to safeguard the home pearl production; and
- c) all pearl production shall be exported to Japan (translated by Sonehara, in George 1978).

The diamond policy was successful for many years, until the Australian and French Polynesian pearl culture industries grew large enough to challenge the Japanese monopoly. Most of the technicians who implant pearl nuclei are, however, still Japanese due to their excellent training program.

The development of pearl oyster culture offers great opportunities to less developed nations. Many of the small island countries of the Pacific are aid dependent and limited in the variety of crops that they can produce; copra and fisheries being a major source of income. Pearl culture can provide substantial export income, thus reducing the aid requirements of the country. The economic potential of pearl culture is best exemplified by French Polynesia, where the production of black pearls (from *P. margaritifera*) has increased

dramatically. The first harvest in 1976 of 6 kg of pearls was worth US\$80,000 (US\$13,333/kg). By 1983, black pearls were French Polynesia's top export earner and in 1989 exports to Japan were worth US\$41.1 million CIF (McElroy 1990). The Cook Islands also has a rapidly expanding black pearl culture industry and production from Manihiki atoll was worth NZ\$6 million in 1991.

Pearl production offers a variety of economic scales and approaches, ranging from commercial companies to cooperatives, families or individuals. Many facets of production do not require a high capital input and are suitable for low technology village production. Pearl oyster shell and meat are valuable commodities and *P. margaritifera* has been farmed since 1905 in the Sudan for the shell alone (Crossland 1957; Mohammad 1976; Rahma and Newkirk 1987).



## TAXONOMY AND DISTRIBUTION

### Taxonomy

Pearl oysters of the family Pteriidae are commercially exploited throughout the world. The two recognized genera, *Pinctada* and *Pteria* occupy a taxonomic position within:

Phylum Mollusca  
 Class Bivalvia  
 Subclass Pterimorphia (Suzuki 1985)  
 Order Pterioida (Suzuki 1985) or Mytiloidea (Richard 1985)  
 Family Pteriidae

The "wing oysters", genus *Pteria*, are characterized by a more elongate shape than *Pinctada* spp., being longer (anteroposteriorly) than wide (dorsoventrally). The posterior ear is often greatly prolonged (Velayudhan and Gandhi 1987). *Pteria penguin* form *macrooptera* is used commercially for the production of "mabe" or half pearls with large-scale commercial culture of this species from hatchery-produced stock being undertaken in the Okinawa Islands. *Pteria* are moderately common throughout the Indo-Pacific, having a wide range from Baja California and Panama in the East through Micronesia, Melanesia, Southeast Asia, East Africa, the Red Sea and the Persian Gulf. *P. penguin* is cultured in Okinawa, Hong Kong, Australia, Thailand and the Philippines. There is a paucity of published material concerning this genus.

The "pearl oysters", genus *Pinctada*, are characterized by a long straight hinge, with the long axis of the shell at right angles to the hinge. The left valve is a little deeper than the right and there is a byssal notch on each valve at the base of the anterior lobe (Rao 1970). They are distributed through the Indo-Pacific and Caribbean regions, with Lessepsian migrants to the Mediterranean (Table 1). The number of species decreases eastwards across the Pacific (Ladd 1960). The taxonomy of *Pinctada* was confused until the definitive version by Hynd (1955). Table 1 gives a sum-

mary of the synonyms used for the three main cultivated species, *Pinctada maxima*, *P. margaritifera* and *P. fucata*.

In recent years electrophoretic methods have been used to differentiate species and identify

Table 1. Taxonomy of *P. maxima*, *P. margaritifera* and *P. fucata*: a chronological summary of synonyms (after Hynd 1955; Rao and Rao 1974).

<i>Pinctada maxima</i> (Jameson 1901)		
1889	<i>Meleagrina margaritifera</i>	von Martens
1899	"Silver and golden lipped pearl shell"	Pace
1899	<i>Meleagrina anomiodes</i>	Melville and Standen
1900	<i>Avicula (meleagrina) margaritifera</i>	Collett
1901	<i>Pteria (margaritifera) maxima</i>	Jameson
1905	<i>Meleagrina maxima</i>	Saville-Kent
1916	<i>Pinctada maxima</i>	Hedley
<i>P. margaritifera</i> (Linnaeus) 1758		
1758	<i>Mytilus margariferus</i>	Linnaeus
1890	<i>Meleagrina radiatus</i> , <i>M. fucatus</i> ,	Saville-Kent
1890	<i>M. cummingii</i>	Saville-Kent
1893	<i>M. cummingii</i> , <i>M. nigro-marginata</i>	Saville-Kent
1899	"Blacklip pearl shell"	Pace
1901	<i>Pteria (Margaritifera) margaritifera</i>	Jameson
1910	<i>Meleagrina margaritifera</i>	Hedley
1916	<i>Pinctada margaritifera</i>	Hedley
1939	<i>P. nigromarginata</i>	Iredale
<i>Pinctada fucata</i> (Gould) 1850		
1785	"Die perlenmuttermuschel"	Chemnitz
1817	<i>Perlamater vulgaris</i>	Schumacher
1850	<i>Avicula fucata</i> , <i>A. lurida</i>	Gould
1857	<i>A. pervidis</i> , <i>A. lacunata</i> , <i>A. occa</i> ,	Reeve
1857	<i>A. fucata</i> , <i>A. aerata</i>	Reeve
1890	<i>Meleagrina aerata</i> , <i>M. lacunata</i> ,	Paetel
1890	<i>M. pervidis</i>	Paetel
1890	<i>M. muricata</i> , <i>M. fucata</i>	Saville-Kent
1899	"Bastard pearl shell"	Pace
1900	<i>Avicula (Meleagrina) fucata</i>	Collett
1901	<i>Pteria (Margaritifera) vulgaris</i>	Jameson
1901	<i>P. (M.) lacunata</i>	Jameson
1910	<i>P. muricata</i> , <i>Meleagrina lacunata</i>	Hedley
1916	<i>Pinctada vulgaris</i>	Hedley
1950	<i>P. panasesae</i>	Allan
1939	<i>P. lacunata</i> , <i>P. aerata</i> , <i>P. pervidis</i>	Iredale

distinct groups among geographically isolated populations (Wada 1982; Blanc 1983; Blanc et al. 1985; Li et al. 1985) and between successive generations (Wada 1986a, 1986c). Differences between *P. margaritifera* from adjacent atolls in the Tuamotu Archipelago, French Polynesia, reflect restricted exchange of larvae between lagoons (Blanc 1983; Blanc et al. 1985). *P. fucata martensii* also showed genetic differences between locations in Japan (Wada 1982, 1984). A greater homogeneity among *P. albina* and *P. maculata* may be due to broader larval dispersal in these species (Wada 1982).

Proteins in pearl oyster hinge ligaments have been used to show the higher order affinity between *P. margaritifera* and *P. maxima* (Kikuchi and Tamiya 1987). Although karyotypes can indicate relationships between higher taxa, no differences occur among *Pinctada* species (Wada 1976a, 1978; Komaru and Wada 1985; Wada and Komaru 1985). Subtle differences between karyotypes are found between *Pinctada* spp. and *Pteria penguin* (Wada and Komaru 1985).

Both environmental and genetic factors influence shell characteristics (Hynd 1960b; Wada 1984). Color, shape, thickness and nacre quality of *P. margaritifera* vary between localities in the Red Sea (Crossland 1957; Reed 1966) and in French Polynesia (Ranson 1957; Domard 1962; Service de la Pêche 1970). Shell size and shape are inheritable in *P. fucata martensii* (Wada 1984, 1986a, 1986b, 1987). Nacre and pearl coloration are also largely genetically controlled (Wada 1983, 1986b), but trace elements and minerals in surrounding waters can have some effect (Mizumoto 1976; Wada and Suga 1977).

Hynd (1960b) used morphometric ratios and shell color to separate the two Australian subspecies of *P. albina*. Shell color patterns and growth rates showed marked geographical discontinuity, but variability in shell shape due to environmental influences meant that any specimen could only be classified from its locality.

The taxonomy, distribution and culture potential of the *Pinctada* species are summarized in Table 2.

Further descriptions and more specific geographical distributions for the four species most extensively cultured - *P. maxima*, *P. margaritifera*, *Pteria penguin* and *P. fucata* - are given below. Differentiation between species is determined mainly by differences in shell character. There are, however, certain differences in the soft parts of the animals the most useful of which is the difference in the shape of the anal funnel. Hynd (1955) described the anal funnel as "a contractile flap-like process of uncertain function attached to the posterior lip of the anus". The shapes of the anal funnels for four species of Australian pearl oysters are shown in Fig. 1. Detailed descriptions for the various species and subspecies can be found in Jameson (1901), Hynd (1955), Rao and Rao (1974) and Velayudhan and Gandhi (1987).

## Species Descriptions

### *Pinctada maxima*

*P. maxima* is distinguished externally by its light fawn color and by having no trace of radial markings. However, in some specimens the umbonal region is colored green, dark brown or purple (Jameson 1901). The nacre has a clear, rich luster which at the distal border can have a golden or silver band of varying width. This gives the species its common name of goldlip or silverlip. The left valve is moderately convex and the right valve flat to slightly convex, the convexity

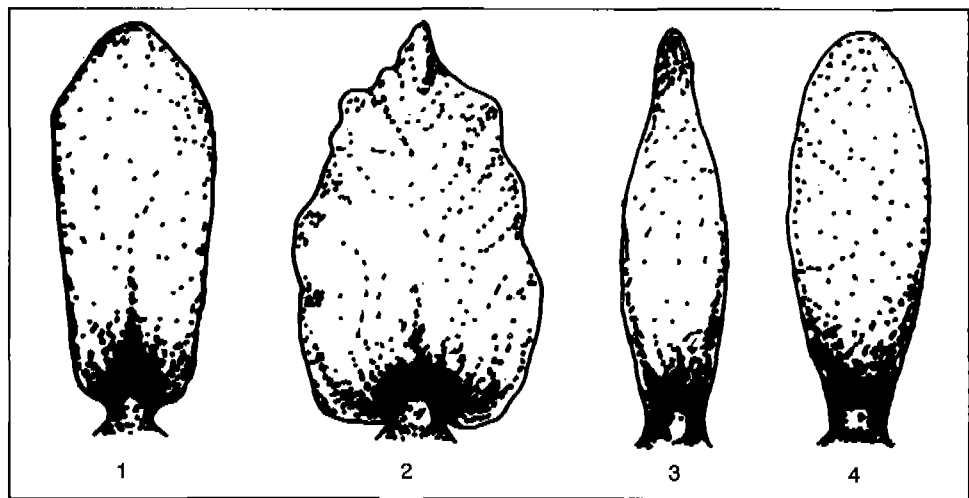


Fig. 1. Anal funnels of four species of Australian pearl oysters. 1. *P. maxima* (Jameson); 2. *P. margaritifera* (Linnaeus); 3. *P. fucata* (Gould); 4. *P. albina sugillata* (Reeve) (Source: Hynd 1955).

decreasing with age. They are less convex, with a longer hinge than *P. margaritifera* (Tranter 1958d). *P. maxima* has no hinge teeth. Growth processes in juveniles are slightly convoluted and two or three times wider distally than proximally. They do not have tapered ends like *P. fucata* or *P. albina*. In mature samples the processes are relatively small and terminate in a blunt point Hynd (1955). It is the largest species of the genus, a pair of valves attaining a weight of up to 6.3 kg (Hedley 1924), and "diameters" of 305 mm (12") (Hedley 1924; Iredale 1939, in Hynd 1955). The right valve is slightly flatter or less convex than the left one. Color morphs of juveniles display the following range of colors: green, purple/black, yellow, cream (white), grey, brown and zigzag patterns of purple/maroon. During the spat/juvenile stage the shell color and mantle are the same color. By the time the oysters are about 120 mm dorsoventral measurement (DVM) the majority of them have brown colored shells. Only the umbo region of the shell will retain the juvenile color. In very old oysters the periostracal layer is often destroyed or worn away so that all evidence of color in the juvenile shell is lost.

### *Pinctada margaritifera*

*P. margaritifera* is distinguished by black coloration to the outer surface of the shell and non-nacreous border. The external shell often shows lighter striations (the stubs of earlier growth processes) radiating from the umbo (Saville-Kent 1893). The silver nacre inside the shell becomes dark or smoky towards the distal rim, hence the name blacklip (Hynd 1955; Salvat and Rives 1980). There are no hinge teeth. The anterior border of the shell extends far in advance of the anterior ear lobe. The shell valves are moderately convex. Maximum sizes of 30 cm "diameter" and 9 kg shell weight have been recorded, with individuals living for up to 30 years (Lintilhac 1985).

### *Pinctada fucata*

*P. fucata* exhibits a variety of color morphs ranging from the commoner reds and browns to greens, bronzes and creams. Three varieties of external patterns are seen. Most often there are a series of continuous radiating rays of a lighter color than the background. A second variety

exhibits regular flecks of color and the third shows even coloration with a darkening on the reference line (the line from the umbo to the furthest edge of the shell). A single specimen can show all three pattern types. The nacre is of a cream to golden color with a hard metallic luster. A single hinge tooth is found at each end of the ligament. It is the most convex of all species with an increase in the ratio of thickness: dorsoventral measurement (DVM) with age (Hynd 1955). The largest specimens are up to 10 cm anteroposterior measurement (APM).

### *Pteria penguin*

*P. penguin* is of dark purple to black external shell color, internally nacreous silver with purple-black margins. The shell is solid, elliptically ovate in outline, the upper valve is more convex than the lower valve and has a rounded keel. The "wings" are either equally sized, or with the posterior wing elongate (var. *macrooptera*). The hinge line is long and straight and has two denticles (Cernohorsky 1978; Springsteen and Leobrera 1986).

## Distribution

*P. margaritifera* ranges from the Gulf of California, Mexico, to the Eastern Mediterranean Sea (see Table 2) (Jameson 1901; George 1978) but reaches its greatest abundances in the atoll lagoons of Eastern Polynesia, from the Tuamotu-Gambier archipelago of French Polynesia to the northern group of the Cook Islands. It extends across the northern coast of Australia from Champion Bay (29°S) in Western Australia to Moreton Bay in Queensland (Saville-Kent 1893; Anon. 1973). There are seven identifiable varieties of the blacklip pearl oyster including *P. margaritifera galtsoffi*, each with its own discrete range. Many early references to *margaritifera* are incorrect (e.g. Simpson and Griffiths 1967) as the name was widely used. Fisheries for blacklip shell have flourished periodically throughout its range. The hydrology of individual lagoons determine abundance, due to larval retention and primary productivity.

*P. maxima* (Jameson 1901) occupies the central Indo-Pacific from Burma to the Solomon Islands. The central portion of this range, Australia,

Table 2. Species and subspecies of the genus *Pinctada*, showing notable references, distribution and culture potential for each.

9

Species and subspecies (synonyms)	Distribution	Notable references	Culture status and potential
<i>maxima</i> (Jameson 1901) ( <i>margaritifera</i> , Gold-lip, Silver-lip)	Australia, PNG, S.E. Asia, Solomon Islands, China (Hainan)	Jameson (1901) Saville-Kent (1890) Hynd (1955)	Cultured in Australia, Okinawa Islands, Philippines, Malaysia, Burma and Indonesia.
<i>margaritifera</i> (Jameson 1901) ( <i>Cumingi</i> , Black-lip)	E. Africa, Persian Gulf, Red Sea, S.W. Indian Ocean, Indo-Pacific	Saville-Kent (1893) Jameson (1901) Hedley (1924) Galtsoff (1933)	Widely cultured in French Polynesia, Cook Islands, Ryukyus Islands, Red Sea and Fiji. Previously cultured on Pacific coast of Mexico.
<i>typica</i> (L.)	Kyukyu Is., Taiwan, Australia, Micronesia, Melanesia, incl. Fiji	Saville-Kent (1893) Hedley (1924) Hynd (1955)	
<i>cumingi</i> (Reeve)	Cook Islands, French Polynesia	Anon. (1956) Gug (1957) Ranson (1962) Coeroli et al. (1982)	
<i>mazatlanica</i> (Hanley)	Baja California, Panama Bay	Jameson (1901)	
<i>erythranensis</i> (Jameson)	Red Sea	Jameson (1901)	
<i>persica</i> (Jameson)	Persian Gulf	Jameson (1901)	
<i>zanzibarensis</i> (Jameson)	East Africa, Madagascar, Seychelles	Jameson (1901)	
<i>galtsoffi</i> (Bartsch)	Hawaii	Galtsoff (1933) Cahn (1949)	
<i>maculata</i> (Gould 1850) ( <i>pitcairnensis</i> , <i>panasesae</i> )	Pitcairn Island, Polynesia, Australia & P.N. Guinea, Red Sea to Tanzania	Hynd (1955) Seurat (1904) Salvat and Rives 1890 Allen (1906) Crossland (1957)	Not cultured.
<i>fucata</i> (Gould 1850) ( <i>vulgaris</i> , <i>muricata</i> , Ceylon, Lingah)	Sri Lanka, India, Australia, Red Sea, Mediterranean <sup>1</sup>	Herdman (1903) Jameson (1901) Saville-Kent (1893) Crossland (1957)	Cultured in India and Sri Lanka.

Continued

Table 2. continued

Species and subspecies (synonyms)	Distribution	Notable references	Culture status and potential
<i>fucata martensii</i> (Dunker 1872) ( <i>muricata</i> , Akoygai, Japan Lingah)	Japan Hollyer (1984)	Jameson (1901)	Cultured throughout Japan as well as in Taiwan, Korea and China.
<i>radiata</i> (Leach 1814)	Arabian Gulf, Red Sea, Mediterranean <sup>2</sup>	Mohammad (1976) Reed (1966)	Limited potential
<i>albina albina</i> (Lamarck 1819) ( <i>carchariarium</i> , <i>imbricata</i> )	Shark Bay Western Australia	Hynd (1955, 1960b)	Limited experimental culture in Shark Bay.
<i>albina sugillata</i> ( <i>sugillata</i> , <i>irradians</i> , <i>fimbriata</i> , <i>scheepmekier</i> , Bastard pearl oyster)	Eastern and Northern Australia, India	Hynd (1955, 1960b) Rao (1967)	Limited culture potential due to poor quality pearls.
<i>imbricata</i> ( <i>radiata</i> , <i>fimbriata</i> , <i>albina</i> )	Central America, Florida, Yucatan	Jameson (1901) Wada (1978) Vokes and Vokes (1983)	Unknown
<i>chemnitzii</i> (Philippi 1849)	Australia, India, China Sea and Japan	Hynd (1955) Velayudhan and Gandhi (1987)	Limited culture potential due to poor quality pearls.
<i>atropurpurea</i> (Dunker 1858)	India	Rao (1967)	No culture potential
<i>anomioides</i> (Reeve 1857)	India	Rao (1967)	No culture potential
<i>nigra</i> (Gould 1850) <sup>3</sup>	Red Sea	Reed (1966)	Unknown
<i>concinna</i> <sup>3</sup> Japan	Matsui (1958)	Unknown	
<i>simizuensis</i> <sup>3</sup> Japan	Matsui (1958)	Unknown	

<sup>1</sup>Early Lessepsian migrant (Vassel 1896, in Jameson 1901).<sup>2</sup>More recent Lessepsian migrant (Kinzelbach 1984; Barash and Danin 1986).<sup>3</sup>Dubious status.



Papua New Guinea and the Philippines, has or had prolific shell grounds (George 1978). The range extends north to Hainan off the coast of China to 25°S on the west coast of Australia and 20°S on the east coast.

*P. fucata* also has a wide distribution from the Western Pacific Ocean (Korea and southern China), Australia, the Indian Ocean to the Red Sea and the Persian Gulf, with Lessepsian migrants (through the Suez canal) into the Mediterranean. The subspecies *P. fucata martensii* is a temperate variety and is found in Japan.

### Species Introductions

There is little information on the movement of species from one area to another. An attempt to introduce *P. fucata martensii* to Morocco failed (Beaubrun 1972). The introduction of *P. maxima* to Suwarrow lagoon in the Cook Islands by Lever Bros. in 1904 was apparently successful at first (Saville-Kent 1905). Within six months of the shell being transplanted spatfall was seen on the mother shells and on surrounding rocks. However, heavy predation by fish and octopii had severely depleted the stock by 1912 and the remaining *P. maxima* evidently disappeared during a hurricane

in World War I. Lever Bros. also attempted, in the same shipment, to introduce *P. maxima* from the Torres Straits in Northern Australia to Christmas Island in 1904. In 1977, introductions of, presumably, *P. margaritifera* were attempted; there are no reports as to the success of these ventures.

There have been repeated attempts to introduce *P. margaritifera* to Rakahanga, Palmerston and Pukapuka lagoons from other areas of the Cook Islands. Although the oysters survived, they did not become established.

The Japanese moved large numbers of *P. maxima* from the Arafura Sea (off Northern Australia) to Palau between the wars, which was for commercial pearl production rather than an attempt to establish the species.

Tasaki Shinju, one of the largest Japanese pearl companies, introduced *P. maxima*, *P. fucata martensii*, *P. margaritifera* and *Pteria penguin* to Tonga in 1975, 1976, 1977 and 1979 at the request of the King of Tonga. It is unclear as to the outcome of these introductions although *P. penguin* has recently been found settled on ropes in Vava'u (Tanaka 1990a).

Species are often moved within their range by Japanese companies for the purposes of selective breeding and hybridization. These movements are generally not recorded in the literature.

## ECOLOGY AND BIOLOGY

### Anatomy

Detailed descriptions of the anatomical structure and function of pearl oysters are found in Herdman (1904), Shiino (1952) and Velayudhan and Gandhi (1987). Provided here are anatomical details of particular relevance to the pearl oyster culturist (Fig. 2).

The pearl oysters conform to the general pattern of structure of the monomyarian lamellibranchs (Rao and Rao 1974), with a single, posterior adductor muscle. The adductor muscle has considerable power and a rapid ratchet-like action. The valves are opened by the elastic-like ligament that joins the two shells.

### Shell

The pearl oyster shell consists of three parallel layers (Fig. 3); the outer, thin, horny coat of the periostracum, the middle prismatic layer of polygonal prisms of calcite, which lie perpendicular to the surface; and the inner nacre which consists of layers of conchiolin, interspersed with thin sheets

of aragonite. The aragonite forms as thin platelets overlapping each other, parallel to the edge of the shell and has zigzag edges. The combination of the shape of the edges and the film-like layers creates the characteristic pearl luster (Herdman 1904; Nakahara and Bevelander 1971; Farn 1986). The nacre has high tensile strength and plasticity compared with other mollusc shells, making it highly resistant to crushing forces and therefore providing good defence against a number of predators (Currey 1977, 1980; Currey and Brear 1984).

Under normal conditions the periostracal layer is secreted from the mantle edge and does not increase in thickness once it is formed. The prismatic layer is secreted from the outer epidermis of the peripheral region of the mantle and is also only laid down once. The nacreous layer is secreted by the entire surface of the mantle and is continually laid down throughout the life of the animal. However, the repair of damaged shell requires the secretion of all layers in the original sequence, regardless of which region is damaged. The mantle therefore must change its secretory faculties in these circumstances (Kawakami 1952a, 1952b). In pearl formation, the three layers are

similarly secreted in order by the inserted mantle tissue around the nucleus. Both shell and pearl formation and composition have been much studied (Hatano et al. 1955; Wada 1961, 1962, 1968; Tsujii 1968a, 1968b; Bevelander and Nakahara 1969; Hatano 1971; Nakahara and Bevelander 1971;) but the actual method of control of shell deposition is still being researched.

The shells of *Pinctada* species have growth processes. These growth processes are described by Hynd (1955) as:

"small scale like projections from the external surface of the shell. They are laid down by the animal at successive intervals at the distal border, and with increase in size they are relegated to the external surface. They are arranged in a pattern consisting fundamentally of concentric circles and radial rows."

The processes are easily knocked off and the number of rows or processes is not

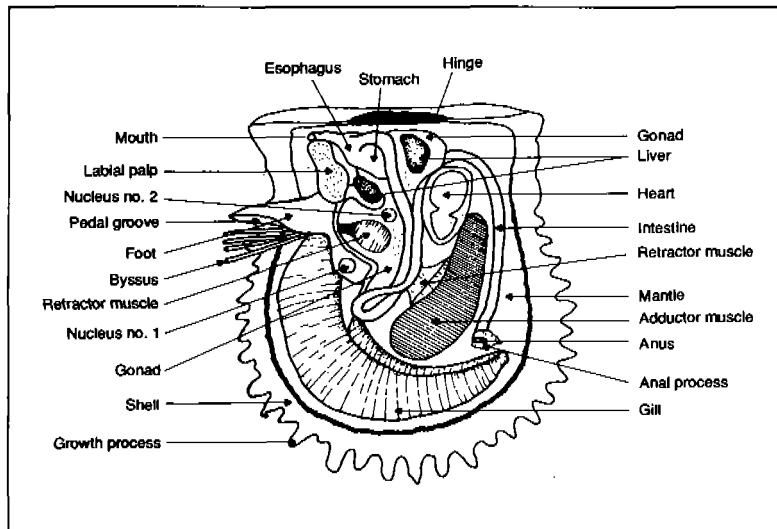


Fig. 2. Internal anatomy of the pearl oyster, based on *P. margaritifera* (adapted from George 1967).

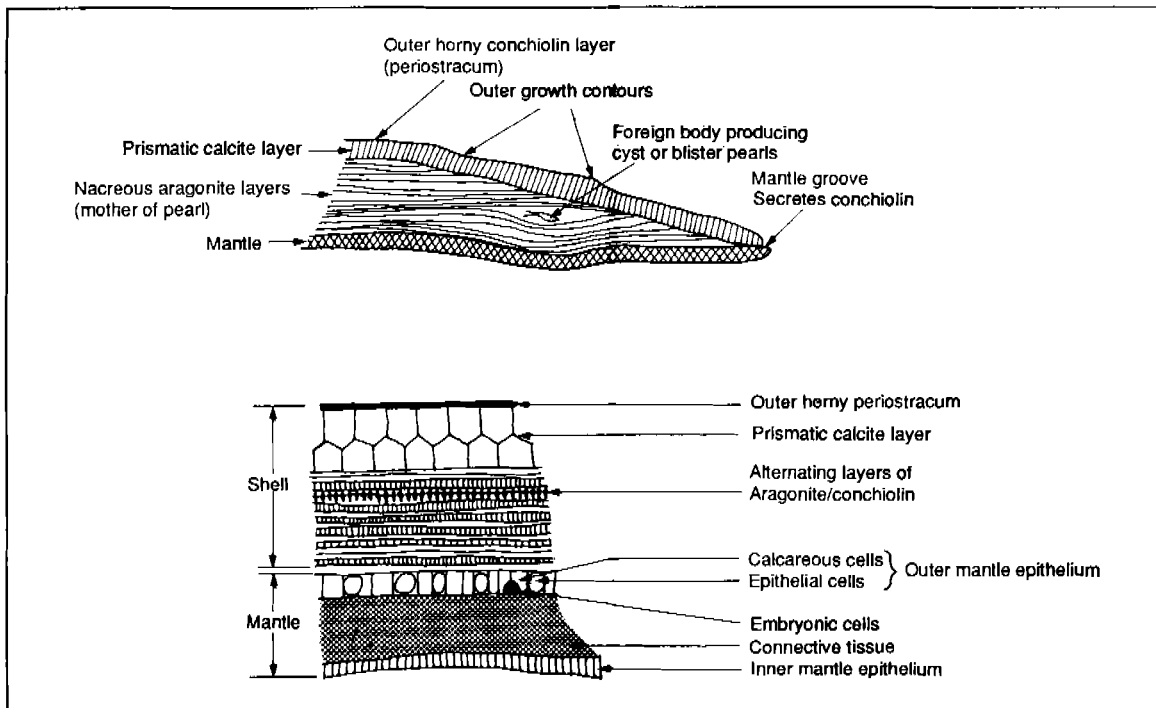


Fig. 3. Cross sections through the shell and mantle of a pearl oyster (after Poirot 1980).

constant even intraspecifics, the number of processes usually increasing with age. In several species the processes bear transverse markings which are useful as diagnostic characters (Hynd 1955).

### **Foot and Byssal Gland**

The foot is a highly mobile, tongue-shaped organ capable of great elongation and contraction. The major part of its bulk is composed of a network of fibers running in various directions, thus ensuring a wide range of movement. Control is provided by the foot retractor and levator muscles with extensive blood spaces providing hydrostatic strength and flexibility (Velayudhan and Gandhi 1987).

The byssal gland is situated at the proximal end of the foot. Byssal fibers are secreted by the byssal gland and pass down the pedal groove which is formed into a tube. Muscular contractions of the foot form the discoid attachment and stem of the thread that is attached to the byssal root. Attachment takes place as the tip of the foot touches the substrate, the byssal secretions harden quickly in seawater. Detailed descriptions of the secretion of the byssus are described for *P. fucata* by Herdman (1903), Dharmaraj et al. (1987b) and

Velayudhan and Gandhi (1987). *P. maxima* spat and juveniles are capable of severing their byssal threads and reattaching elsewhere. Strong byssal attachments are retained up to about three years of age. Older free-living adults are kept in position by their shell weight (Saville-Kent 1890, 1893). *P. margaritifera* usually retains its byssus throughout its life. If severed, a new byssus may be secreted within a week (Nicholls 1931), but both adults and juveniles will survive unattached. *P. fucata* is capable of severing its own byssus, moving and reattaching at a new location (Herdman 1903; Kafuku and Ikenoue 1983).

## **Environmental Factors**

### **Temperature**

Temperature limits vary between species and are the main influence on their distribution. Extension of *P. margaritifera* down the Eastern Australian coastline is clearly temperature related (Hynd 1955; George 1978), with *P. margaritifera* from the southern Great Barrier Reef "deformed or stunted" (Hynd 1955).

The temperature range within the Australian *P. maxima* fishery is from 19 to 32°C, with *P.*

*margaritifera* having a similar range. *P. fucata martensii*, being a temperate variety, has a temperature range of 10-25°C (Alagarwami 1970) with hibernation taking place below 13°C (Kafuku and Ikenoue 1983). Numaguchi and Tanaka (1986b) considered the optimum temperature for spat of *P. fucata martensii* to be 17.5-29°C with an upper limit of 32°C and a lower limit of 15°C.

Cold water reduces the heart rate, slows growth rates, hinders reproductive development and renders pearl oysters more vulnerable to infection. Yamashita (1986) reported heavier mortalities on stressed *P. maxima* during winter. Dybdahl and Pass (1985) and Pass et al. (1987) found heaviest mortalities in cultured *P. maxima* during the colder months. *P. fucata martensii* hibernates in temperatures less than 13°C and suffers from heat stress in temperatures greater than 28°C. Temperature is the most important factor relating to gonad development and spawning seasonality, as will be discussed in the section on reproduction.

The temperature also determines the rate of deposition of nacre both on shells (Cahn 1949) and on nuclei (Watabe 1952; Alagarwami 1975) and therefore limits pearl culture sites to areas within the optimum temperature ranges. However, although the growth of pearls is reduced with lower temperature, the quality or luster is improved due to the thinner layers of nacre and so most harvesting of pearls is carried in the winter.

### Depth

The upper limit of most of the *Pteriidae* is within the intertidal zone, although in many areas it is unusual to find any of the commercial species in waters shallower than 10 m, owing to commercial fishing pressure. *P. maxima* has a depth range of 0-80 m, with the depth limit being dependent upon location. *P. margaritifera*, which is naturally most abundant around the low tide mark, extends to depths of 40 m in the Torres Straits and Polynesia (Hynd 1955; Intes 1982b; Intes and Coeroli 1985a; Intes et al. 1986; Sims 1990), to 27 m in the Red Sea (Reed 1962, 1966) and to 18 m in Pearl and Hermes Reef, Hawaii (Galtsoff 1933). *P. fucata* is found from the intertidal zone to 30 m.

Natural reserves of larger, unfished pearl oysters are often supposed to exist in deeper waters, ensuring continuing recruitment into the fishable,

shallower stocks (Galtsoff 1933; Gug 1957; Domard 1959, 1962; Hynd 1960a; Service de la Pêche 1970; Intes 1982a; Penn and Dybdahl 1988). These deepwater reserves and their significance to management strategies are largely unproven.

Depth affects growth of pearl oysters. *P. maxima* taken from 73 to 82 m were "of smaller size and less growth" (George 1978). *P. fucata* held near the surface grew faster than at 15-16 m (Hornell 1915). Poor growth reported in *P. fucata martensii* cultured near the surface was probably due to heavy wave action and movement of the culture lines (Yoo et al. 1986). The poor growth rate in deeper water is probably a result of both lower temperatures and reduced densities of phytoplankton.

The quality and color of pearls also vary with depth as a result of both light and temperature. Below 5 m, *P. fucata martensii* produces high quality, pinkish pearls (Kafuku and Ikenoue 1983). Nacre deposition is maximized under blue light (Cahn 1949), similar to that in deeper water.

### Salinity

Pearl oysters have a preference for full salinity seawater but most can tolerate a wide range of salinities. This is a common phenomenon in organisms that inhabit the intertidal zone.

The natural range of *P. fucata martensii* is 27.2-33.7 ppt (Kafuku and Ikenoue 1983). Salinity tolerance has been measured by various methods (Kawamoto and Motoki 1954; Alagarwami and Victor 1976; Numaguchi and Tanaka 1986a). Results have been dependent upon the criteria used, the time of exposure, the age of the pearl oysters and other stresses. Heavy mortalities of *P. fucata martensii* larvae occurred at 11.4 ppt, but growth of larvae was not affected from 19 to 37.9 ppt (Numaguchi and Tanaka 1986a). Adult *P. fucata martensii* "might be in danger of dying" after 24 hours exposure below 10 ppt (Kawamoto and Motoki 1954), but limits for *P. fucata*, estimated over 2 to 3 days were between 24 and 50 ppt (Alagarwami and Victor 1976). Conditioning time increases the further the salinity is from the norm (35 ppt).

The Japanese prefer to culture *P. fucata martensii* in bays where there is an influx of freshwater, as the pearls produced from oysters grown in these areas do not get the same golden tint as those grown in full salinity water

(Alagarwami 1970). This technique is not used in the *P. maxima* culture industry and may not apply.

### **Substrate and Silt Load**

Substrate availability is the factor that most limits the distribution of *Pteriidae* in areas that would otherwise be ideal habitats. *P. margaritifera* is scarce or absent in some lagoons in French Polynesia due to limited substrate availability (Service de la Pêche 1970). The species is excluded from soft bottoms (Galtsoff 1933; Intes 1982a, 1988; Intes and Coeroli 1985b; Intes et al. 1986) but was reported "only on the sand" in Onotoa Atoll, Kiribati (Banner 1952).

Adult goldlip occur on mud or sand, often in association with seagrass beds (Hedley 1924) but this may be a result of having been shifted to these areas after the detachment of their byssus at about three years of age. Spat will only settle upon a hard substrate and in Western Australia an aggregate or a seabed with a hard crust that covers a softer substrate is considered ideal for *P. maxima*.

*P. fucata* occurs on extensive shoals, or paars, in the Gulf of Mannar (Herdman 1903, 1904; Hornell 1914a, 1914b, 1915, 1922). These are rocky or dead coral outcrops often with a dense growth of marine algae. Due to storms or currents entire beds of juveniles may be smothered by shifting sediments (Herdman 1903; Nayar et al. 1978; Nayar and Mahadevan 1987).

Pearl oysters are nonspecific feeders and if the silt load in the water is high feeding will be affected. A decline in the condition of oysters kept at Veppalodai in the Gulf of Mannar was thought by Chellam et al. (1987a) to be mainly due to the high silt loading in the area.

### **Currents**

Beds of *P. maxima* are often found in areas of very strong currents. Reasonable currents are required in culture areas for ongrowing, both to bring food and oxygen to the site and to remove feces and pseudofeces. Areas of reduced currents are used for *P. fucata martensii* when spat are first put into the sea from hatcheries and immediately following the pearl implantation (M. Gervis, pers. obs.).

Strong currents promote growth in *P. maxima* (Saville-Kent 1890, 1893) and *P. margaritifera galtsoffi* (Galtsoff 1933). Although nacre layer formation is more rapid under strong currents, poorer quality pearls are produced (Kafuku and Ikenoue 1983).

The strength of the currents in many areas of Australia limits the amount of time that divers can spend servicing the culture areas.

### **Pollution**

Pearl oysters are exceptional accumulators of zinc and cadmium, showing potential as heavy metal indicator species (Shiber 1980; Jacob et al. 1980; Klumpp and Burdon-Jones 1982; Ikuta 1986a, 1986b, 1987). Cadmium levels in *P. carchariarium* from the unpolluted waters of Shark Bay, Western Australia, were more than twice the allowable level for human consumption (McConchie et al. 1988).

Pollution impacts on pearl oysters are usually only reported where catastrophic mortalities result. Mortalities of 80-100% occurred directly after the Oceanic Grandeur oil spill in the Torres Strait in 1970 (Yamashita 1986). It is therefore possible that the oil pollution released during the 1991 Gulf war will have had devastating effects on the Persian Gulf stocks.

Mortalities of more than 26% of cultured *P. fucata* in Veppalodai, India, were attributed to environmental deterioration caused by increased shrimp trawler activity (Chellam et al. 1987b).

The Japanese pearl industry based on *P. fucata martensii* had a rapid expansion in production levels from 3.75 t of pearls produced in 1950 to 127.46 t in 1966 (Mizumoto 1976). This was followed by a slump in production as a result of high mortalities and a drop in the price of pearls. Both the mortalities and the reduced prices (due to poorer pearl quality) were thought to have been a direct result of pollution. Pollutants from the pearl farms themselves were the main cause of the heavy mortalities. Pearl washing and bleaching slurries were dumped directly into farm waters (Hollyer 1984). Fecal pollution from pearl oysters and fecal and feed pollution from the yellowtail culture industry resulted in anoxic sediments in the culture areas. Although production levels again increased and reached up to 71 t in 1988 from a low of 30 t in 1974 (Kafuku and Ikenoue 1983; McElroy 1990), there are still problems. Environ-



mental awareness has been increased and yellowtail culture grounds are now kept separate from areas of pearl culture. However, in the traditional culture grounds such as Ago Bay there is no longer any natural spatfall of *P. fucata martensii* (Ward 1985).

### Food and Feeding

Primary productivity requirements and sediment tolerances vary between species. *P. margaritifera* inhabits the oligotrophic waters of atolls and coral reefs (Tranter 1959), where productivity may be low (Raymont 1963; Larkum 1983). The shelf habitat of *P. maxima*, *P. fucata* and *Pteria penguin* has greater terrigenous sediment and nutrient inputs and higher productivity levels. *P. fucata martensii* being a temperate variety lives in waters with a higher primary productivity level than that required by *P. margaritifera*, *P. maxima* or *Pteria penguin*.

The basic processes of feeding in pearl oysters, Kuwatani (1965a, 1965b), are similar to other filter-feeding bivalves (Yonge 1960; Jorgensen 1970). There is still debate on the degree of selectivity of feeding in bivalves; some bivalves feed selectively filter-specific microalgal nanoplankton (Yonge 1960; Jorgensen 1970), while others indiscriminately feed on all particulate matter (Mansour 1946a, 1946b; Korringa 1952; Mansour and Gabal 1980).

The ingestion of large amounts of mud, other inorganic material, bivalve eggs and larvae (Ota 1959; Chellam 1983; Jacob et al. 1980; Nasr 1984) suggests nonselective feeding in *P. margaritifera*, *P. albina (vulgaris)*, *P. fucata*, *P. radiata* and other species (Mansour 1946a, 1946b; Mansour and Gabal 1980). Inefficient feeding mechanisms may explain the exclusion of *P. margaritifera* from the turbid waters of some closed lagoons in Polynesia, such as Rakahanga and Reao.

Microalgal components of pearl oyster diets and resulting growth were examined by Herdman (1903), Numaguchi (1985) and Teshima et al. (1987) for adult pearl oysters (larval diets are given in the section on hatchery production). Broodstock are fed a mixed algal diet by culturists for conditioning. *Chaetoceros* sp., *Isochrysis* sp., *Pavlova* sp., *Chlorella* sp., *Nannochloris* sp., *Phaeodactylum* and *Tetraselmis* sp. are recommended for *P. fucata* (Hayashi and Seko 1986; Alagarwami et al. 1987).

## Reproduction

### Sexuality

There have been a number of studies conducted on the reproductive biology of different species of the genus *Pinctada*. These studies reveal that most aspects of the sexual history are common to all species. They are protandrous hermaphrodites with the ratio of males to females tending to 1:1 with increasing age. A sex ratio approaching 1:1 is found in *P. maxima* over 200 mm (Rose et al. 1990). Both male-to-female and female-to-male sex changes can occasionally be seen in gonad sections; hermaphroditic phases are transitional and not functional. Change in sex can occur in all members of the genus after male maturity has been reached. These changes are reversible and may be brought about by stress (Cahn 1949; Tranter 1958a, 1958b, 1958c, 1958d, 1959; Service de la Pêche 1970; Millous 1977; Chellam 1987; Rose et al. 1990;). Sex reversal also occurs in Ostreidae, Teredinidae and Pectinidae (Tranter 1958d) and may be related to a "weak hereditary sex determining mechanism" as hypothesized for *P. albina* (Tranter 1958b).

Male maturity occurs for *P. maxima* at 110-120 mm (Rose et al. 1990), full maturity occurs in *P. margaritifera* in the second year (Crossland 1957; Talavera and Faustino 1931, in Tranter 1958a) while the smaller, shorter-lived species mature and spawn within a year, *P. albina* spawning at four months (Tranter 1958a) and *P. fucata* possibly spawning twice in the first year.

No differences in shell morphology are associated with change of sex. Gonad coloration distinguishes sex in *P. margaritifera* "with an error of less than 5 per cent" (Tranter 1958d). Ovaries are pinkish (Tranter 1958d), creamy, or yellow and granular, testes are white and smooth. (Crossland 1957; Reed 1966). Gonad color may also be used to determine sex in *P. maxima* and *P. albina* (Tranter 1958a; Rose et al. 1986) but is not a reliable criterion in *P. fucata* (Tranter 1959; Velayudhan and Gandhi 1987).

### Maturity

*P. maxima* and *P. margaritifera* mature later than the smaller species of *Pinctada*. The blacklip pearl oyster reaches full maturity in the second year (Crossland 1957; Talavera and Faustino 1931,

in Tranter 1958a; Tranter 1958d; Reed 1966). *P. maxima* matures as a male 110-120 mm during its first year of life (Rose et al. 1990). Smaller, short-lived *Pinctada* develop faster, with *P. albina* reaching maturity in only four months (Tranter 1958a). Hatchery-reared, farm-cultured *P. fucata* spawned at nine months (Chellam 1987) and wild *P. fucata* possibly spawn twice in the first year (Tranter 1959).

### **Gonad Development**

The gonad is not a discrete organ, being found between the connective tissue at the base of the foot and the intestinal loop. As ripening gonads

increase in size, follicles and germ cells extend through the connective tissue, filling the cavity between the foot and byssal gland, around the retractor muscle and digestive tract (Seurat 1904; Tranter 1958a, 1958b, 1958d, 1959).

A ripe individual is identifiable superficially by the size of the gonad and microscopically by the abundant gametes and fewer germ cells in the follicles (Tranter 1958a). Tranter (1958c) defined eight stages of gonad development in *P. albina*, but Chellam (1987) defined five and used only three for *P. fucata*. Rose et al. (1990) simplified the scheme developed by Tranter (1958b, 1958c) for *P. albina* in their work on *P. maxima* and their scheme is shown in Table 3. Seasonal varia-

Table 3. Gonad developmental stages of *P. maxima* (from Rose et al. 1991, adapted from a scheme developed by Tranter (1958b, 1958c) for *P. albina*).

<b>Stage 0: Indeterminate or inactive</b>	
No evidence of gonadal development, except empty, collapsed follicles and connective tissue containing different types of granulocytes and phagocytes.	
<b>Stage 1: Early gametogenesis</b>	
MALE	FEMALE
Follicles initially small and lined with stem cells and spermatogonia. As spermatogenesis proceeds, primary and secondary spermatocytes rapidly proliferate, filling up the follicular lumen.	Follicles initially small, poorly formed and empty, with walls lined with stem cells and developing oocytes. Oogonia and early (or primary) oocytes have little or no yolk, each with a large nucleus, and often adhere to the follicular wall in clusters. As oogenesis proceeds, oogonia and young oocytes proliferate along the inside walls with a few larger oocytes beginning to elongate.
<b>Stage 2: Actively developing to near-ripe gametogenesis</b>	
Follicles begin to enlarge with spermatogonia and spermatocytes proliferating along the periphery of the lumen and with spermatids and some spermatozoa filling the center. Near-ripe follicles have enlarged greatly with developing sperm appearing. Except for isolated pockets of spermatocytes and spermatids, the follicular lumen is packed with spermatozoa.	Oocytes connected to the follicular wall have begun to accumulate yolk and expand into the lumen, with a few free oocytes appearing in the center. Near-ripe follicles are densely packed with mainly large elongated oocytes; these are still connected to the follicular wall by a long, narrow stem of yolk material.
<b>Stage 3: Spawning-ripe</b>	
Follicles distended, confluent and almost entirely filled with spermatozoa. Spermatocytes and spermatids are restricted to lining the follicular walls which have become increasingly thinner with maturity	Confluent follicles packed with almost entirely free, polygonal-shaped oocytes displaying both a nucleolus and nucleus.
<b>Stage 4: Partially spawned to spent</b>	
Gonad containing follicles with partially empty lumen. Those which are still full have a gap between the follicular wall and the mass of spermatozoa remaining in the lumen. Partially spawned follicles contain phagocytes amongst spermatozoa. Spent follicles are empty except for small packets of residual sperm and phagocytes inhabiting the lumen. Redevelopment can be seen along the walls of some follicles.	Follicles are partially empty, with small amounts of resorptive material occurring in the space between free oocytes which have become rounded or pear-shaped. Follicles which are almost completely spent have extensive redevelopment occurring along the inside follicular wall, with large amounts of resorptive material surrounding free oocytes undergoing cytolysis. Spent follicles are almost entirely empty with no sign of gametogenesis except for isolated regressing oocytes surrounded by resorptive tissue, phagocytes and interstitial connective tissue.

tions in glycogen, lipid, cholesterol and protein in *P. fucata* correspond to reproductive cycles (Desai et al. 1979). *P. maxima* broodstock monitored for gonadal development took at least five weeks to mature from indeterminate/early developmental stages to spawning ripe stages regardless of sex (Rose et al. 1990).

### Spawning Seasonality

Spawning is often associated with temperature extremes or sudden changes in the environment. As with many marine species (Orton 1928; Pearse 1974), pearl oysters from temperate regions generally exhibit more discrete, regular spawning seasons. Spawning in tropical pearl oysters is not limited to any single season and protracted spawnings may occur throughout the year. Reproductive seasonality was best considered as "relative breeding intensities", with "major breeding season(s)" rather than discrete spawning periods (Tranter 1958c). Although warm water controls development, cold water will also induce spawning (Tranter 1958c; Millous 1980; Chellam 1987). In Japan, *P. fucata martensii* spawning is induced prior to pearl implantations by overcrowding the pearl oysters in deeper, colder water (Kafuku and Ikenoue 1983; Hollyer 1984). *P. fucata martensii* in Japan spawns between May and September with peak spawning in June and July. Ripening in *P. fucata martensii* requires around 800 degree-days of temperature exposure above 13°C (Wada 1976b).

Maximum spawning intensity in *P. margaritifera* is usually in summer and winter, but varies between spawning locations and years. Blacklip in the Red Sea have a discrete breeding season; in more tropical areas the spawning season is less discrete. *P. fucata* spawning is almost continuous in India although spawning peaks may coincide with both increases and decreases in water temperature or the onset of southwest and northeast monsoons (Appukuttan 1987). *P. maxima* in Australia spawns from September/October to March/April with a primary peak at the beginning of the season and a secondary one at the end (Rose et al. 1990).

Although temperature is the main factor determining sexual development and initiating spawnings, the frequent occurrence of limited spawnings outside of the recognized breeding periods (Tranter 1958d) suggest that groups of pearl oysters respond to local stimuli. These can include

a reduction in salinity, changes in currents, calm seas, crowding and other stresses such as handling and exposure to the air. In hatcheries, chemical or thermal induction is used to produce viable eggs (Tanaka and Kumeta 1981). Further techniques for spawning induction are discussed in the section on hatchery production.

### Spawning Process

Spawning is usually incomplete, with some resorption of gametes. Tranter (1958d) found *P. margaritifera* emitted almost all of their gonad material, but Bullivant (1962) noted two-thirds of gonad material remaining after spawning. *P. maxima* is reported to be a multiple spawner (Rose et al. 1990).

Spawning is accomplished by muscular contractions, rather than ciliary actions (Tranter 1958a), with intermittent, successive extrusions lasting a minute or two, rather than forceful closure of the valves (Bullivant 1962).

*P. margaritifera* oocytes are activated in the follicle immediately prior to spawning (Tranter 1958d). Stripping of gonads cannot therefore produce viable eggs, presenting a tremendous hurdle (Tranter 1959) to early attempts at hatchery culture.

### Larval Development

Pearl oysters release sperm and eggs into the water where fertilization takes place. The unfertilized eggs are irregular or pyriform, becoming spherical when fertilized. The larval life ranges from 16 to 30 days depending on species, temperature, nutrition and the availability of settlement substrates. Larval growth and survival is largely dependent on the food supply (Yuki and Kobayashi 1950, in Matsui 1958; Wada 1973, 1984; Alagarwami et al. 1983a, 1983b; Numaguchi and Tanaka 1986a, 1986b; Yi 1987). The larval stages and length of time required to reach each stage for the three main species under culture are detailed in Table 4.

The veligers swim by means of their ciliated velum and, being positively phototactic, remain near the surface (Nayar and Mahadevan 1987). As the larvae approach settlement, a foot develops by which the larvae can crawl about the substrate while searching for a suitable place to settle. Larvae are able to control the settlement location by shortening or prolonging the planktonic and crawl-

Table 4. Larval size at age for *P. fucata*, *P. maxima* and *P. margaritifera*. Adapted from Alagaraswami et al. (1989).

Stage	<i>P. fucata</i>					
	Alagaraswami et al. (1983b)		Ota (1957) and others		Minaur (1969)	
	Size (mm)	Age	Size (mm)	Age	Size (mm)	Age
Egg spherical	47.5	-	-	-	59-60	-
D-shape	67.5 x 52.5	20h 40m	72 x 60	20h	-	-
Early umbo	100 x 95	-	96 x 87	d 8	96 x 87	d 5
Umbo	135 x 130	d 10-12	-	-	125 x 112	d 12
Eye spot	210 x 190	d 15	170-200	-	-	-
Pediveliger	230 x 200	d 20	209 x 195	d 25	180 x 160	d 14-20
Plantigrade	250 x 240	d 22	200-230	-	-	-

Stage	<i>P. maxima</i>				<i>P. margaritifera</i>	
	Tanaka and Kumeta (1981)		Rose and Baker (1989)		Alagaraswami et al. (1989)	
	Size (mm)	Age	Size (mm)	Age	Size (mm)	Age
Egg spherical	-	-	60	-	45	-
D-shape	57-77	20h	75-80	24h	75 x 60	24h
Early umbo	110-125	d 10	110-110	d 6	110 x 90	d 9
Umbo	-	-	120-130	d 8	140 x 130	d 12
Eye spot	-	-	115-250	d 15	210 x 200	d 16
Pediveliger	234	d 19	120-280	d 18	220 x 210	d 20
Plantigrade	233-281	d 21	260-330	d 18-25	260 x 240	d 23

Note: Where two measurements are given with an x sign the first is APM and the second DVM (see page 17). Time from fertilization is given in minutes (m), hours (h) and days (d).

ing pediveliger stages (Herdman 1903). After settlement some motility is retained and the foot can be used to crawl away from unfavorable conditions.

Juveniles use byssal threads to attach themselves to the substrate. They have the ability to replace severed byssal threads (Allen 1906) and this is used to advantage in farming operations.

## Growth

In edible bivalve culture and pearl shell fisheries, growth rates and returns are assessed by weight of meat or shell. For the production of pearls, however, such growth rate per se is not the sole commercial factor to be considered. Aspects such as the size and retention/rejection ratios of implanted nuclei, postimplantation survival,

rate of nacre deposition on the nuclei and the eventual quality (color, shape, luster) of the resultant pearl have all to be taken into consideration. As larger pearl oysters allow bigger nuclei to be implanted, Wada (1984, 1986a, 1986c) justified the use of shell dimension criteria when crossbreeding *P. fucata martensii*. Fast growth is obviously desirable. Growth rate may be slowed, however (for example, for laying the final coats of nacre on a pearl prior to harvesting), by changing the location of the oysters and thus the environmental conditions. Fast growth and good health of *P. maxima*, *P. margaritifera* and *P. fucata* are indicated by the length and profusion of growth processes (Nicholls 1931; Hynd 1955; Tranter 1958d). Normal growth is characterized by fast initial increases in the dorsoventral measurement (DVM), to a near maximum size, subsequent to which the shell thickness increases.

In *P. margaritifera*, a shell "diameter" of 7 or 8 cm is attained within one year (Service de la Pêche 1970), reaching around 11 cm by the second year (Coeroli et al. 1982; Coeroli 1983). After two years, *P. maxima* average 10-16 cm (Sagara and Takemura 1960; R. Dybdahl, pers. comm.), with the largest being 18-19 cm (Hancock 1973). After two years increases in shell diameter are small. Maximum average shell diameters of 14-17 cm are reported for *P. margaritifera* (Coeroli et al. 1982; Coeroli 1983), and 20-25 cm for *P. maxima* (R. Dybdahl, pers. comm.).

Smaller, shorter-lived species demonstrate proportionally faster growth. With a lifespan of only about four years, *P. fucata* reaches a maximum DVM of 9 cm within the first twelve months (Tranter 1959). Growth declines markedly thereafter (Kobayashi and Tabota 1949a, 1949b; Devanesan and Chidambaram 1956, both in Chellam 1978; Mohammad 1976; Nalluchinnappan et al. 1982).

### Shell Dimensions

Hynd (1955) clarified the expressions that may be used to describe the dimensions of pearl oysters. These are shown in Fig. 4 and described below.

#### Dorsoventral measurement (DVM)

Tranter (1958a) defined DVM as the longest axis in the dorsoventral direction. DVM may be the greatest distance from the umbo, or original point of growth, to the furthest margin (Nalluchinnappan et al. 1982; Nasr 1984; Sims 1990). Alternatively, DVM can be a line drawn perpendicular to the hinge line across the greatest dorsoventral distance. This dimension is also known as shell height. This is of greater utility in studies of shell shape (e.g., Herdman 1903; Hynd 1955, 1960a, 1960b; Alagarwami and Chellam 1977; Chellam 1978), but has also been used for growth studies (Nicholls 1931). DVM growth can vary markedly between individuals (Nicholls 1931; Tranter 1959), but is the best dimension for measurement

of comparative growth and is widely used in field trials.

#### Anteroposterior measurement (APM)

The anteroposterior measurement is the greatest horizontal distance between the anterior and posterior margins of the shell taken parallel to the hinge line. This measurement may also be referred to as shell length. The anteroposterior distance was used by Herdman (1903) for *P. fucata*, but was found to be unreliable in *P. margaritifera*, due to the profusion of growth processes on the anterior and posterior borders (Nicholls 1931). This dimension tends to be used more extensively when measuring larvae.

#### Hinge length

The hinge length is the distance between the tips of the anterior and posterior ears along the hinge line (Alagarwami and Chellam 1977). It is a dimension that has been used in various growth and taxonomic studies both for adults and spat (Hynd 1960b; Narayanan and Michael 1968; Chellam 1978; Numaguchi and Tanaka 1986a, 1986b).

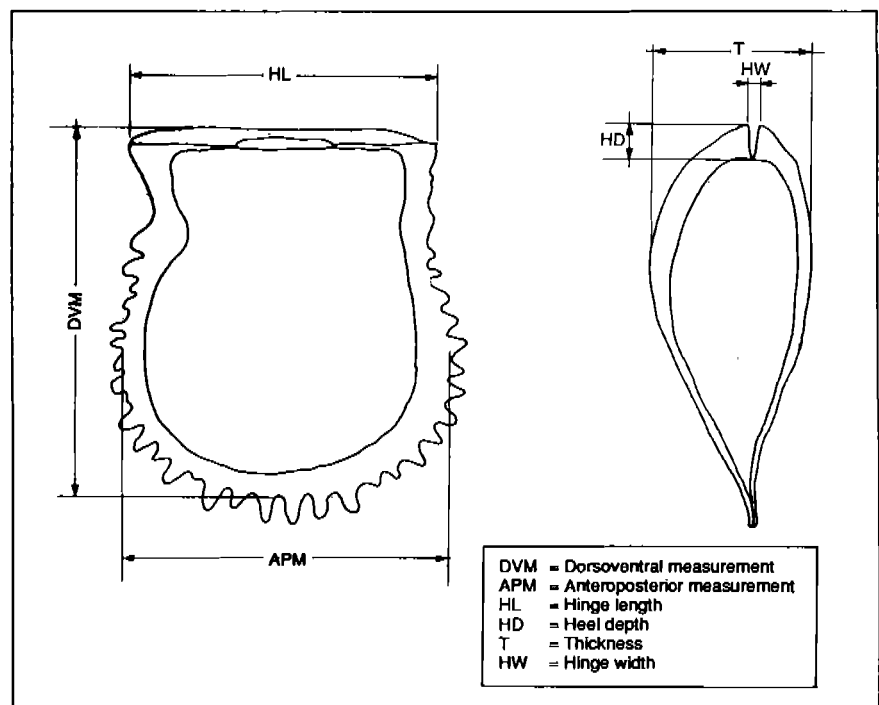


Fig. 4. Shell dimensions of pearl oysters, as used in growth measurements.



## Heel depth

Heel depth represents the thickness of the valve at the hinge line (Tranter 1958a), but the exact method of measurement is not specified. Potential errors in measurement probably increase with age, as bioerosion and fouling increase.

Although there is much variability between individuals (Sims 1990), heel depth is still considered the most reliable indicator of age in *P. margaritifera* (Service de la Pêche 1970; Mohammad 1976). The continual secretion of nacre throughout the life of the pearl oyster explains the linear relationship of heel depth with age.

## Thickness and hinge width

Thickness is the maximum distance between the external surfaces of the two valves when they are closed. This dimension is also known as shell width. The hinge width is the maximum gape between the dorsal borders of each hinge line. These dimensions were both found to increase constantly with age in *P. fucata* (Narayanan and Michael 1968, in Mohammad 1976; Chellam 1978).

## Weight

Economic yield in pearl shell fisheries is best assessed by shell weight. Measures of the amount of shell deposited, rather than flesh weight increases are significant. Potential errors arise, however, due to biofouling.

Total weights have been monitored for *P. fucata* (Chellam 1987). Average flesh weight for each heel depth class was considered to be the best measure of age in *P. carchariarium* (McConchie et al. 1988).

## Morphometrics

Comparative growth studies can monitor changes in ratios to assess the effects of various

treatments, such as stressing, different growth conditions or areas or the change in form of the oysters with age (Galtsoff 1931; Alagarwami and Chellam 1977; Yoo et al. 1986; McShane et al. 1988). Younger or fitter pearl oysters generally demonstrate faster dorsoventral growth (Galtsoff 1931; Alagarwami and Chellam 1977). Morphometric relationships can also be used to differentiate between genetic groups (Hynd 1960a, 1960b; Alagarwami and Chellam 1977; McConchie et al. 1988).

Table 5 summarizes the published estimates of the length:weight relationship of various species showing increases in line with the cube law.

## Growth Rates

Growth parameters are poorly documented for *Pinctada* species. Chellam (MS) (in Chellam 1987) estimated von Bertalanffy parameters for *P. fucata* at  $L_{\infty} = 79.31$  mm,  $K = 0.0756$  and  $t_0 = 0.44$  months.

Sims (1990) found von Bertalanffy parameters of  $K = 0.26$  and  $L_{\infty} = 183$  mm in wild stocks of *P. margaritifera* in the Cook Islands. Cultured *P. margaritifera* parameters varied from  $K = 0.254$ ,  $L_{\infty} = 310$  mm, on a longline to  $K = 0.528$ ,  $L_{\infty} = 157$  mm on a crowded shallow-water trestle platform. Mean parameters were  $K = 0.353$ ,  $L_{\infty} = 181.7$  mm. Two calculations were used to compare *P. margaritifera* growth between trials:  $\phi'$  (Pauly and Munro 1984,  $\phi' = \log K + 2 \log L_{\infty}$ ); and  $T_{(120)}$ , the time taken to reach a commercial size of 120 mm ( $t_0 = -0.71$  years);  $\phi'$  values ranging between 4 and 4.4 for longline culture stock with  $T_{(120)}$  values for cultured stock with  $T_{(120)}$  values between 1.2 and 2.9 years. Platform cultured stock had  $\phi'$  values between 4.1 and 4.3 with  $T_{(120)}$  values ranging from 2 to 2.2 years. Deepwater (35 m) trials with natural stock showed markedly slower growth with  $\phi'$  values of 3.67-3.77 and  $T_{(120)}$  between 6.5 and 6.8 years compared to natural stock at a depth of 15-17 m where  $\phi'$  was 4.02 and  $T_{(120)}$  2.7 years.

Table 5. Length-weight relationships for two *Pinctada* species. (W is expressed in g and L in cm).

Species	Formula	Reference
<i>P. margaritifera</i>	$W=0.14 L^3 + 6$	Derived from Coeroli (1983)
<i>P. m. galtsoffi</i> *	$W=0.04209 L^{3.2153}$	Galtsoff (1931)
<i>P. fucata</i>	$W=0.145 L^{3.0428}$	Derived from Alagarwami and Chellam (1977)
<i>P. fucata</i>	$W=0.1322 L^{3.0414}$	Yoo et al. (1986)
<i>P. fucata</i>	$W=0.0908 L^{3.222}$	Yoo et al. (1986)

\*This equation gives a very low value of W and appears to be incorrect.

Growth data recorded by Nicholls (1931), Coeroli et al. (1984) and Nasr (1984) for *P. margaritifera* also showed wide variation and demonstrates the effects on growth of temperature, depth, culture method and fouling.

Heel depth increased linearly in *P. fucata* at around 2 mm per year, irrespective of environmental conditions (Tranter 1959). Heel depth was therefore considered an indispensable aid in age determination in *P. fucata* (Tranter 1958a, 1958d, 1959). Linear growth permits simple expression of increases in size as absolute units (e.g., cm per year), but does not represent bivalve growth over the full life of the animal. It is still valid for comparing growth in single trials where all individuals are the same age and size-class (Yoo et al. 1986). Linear growth in *Pinctada* is reported by Pandya (1976), Mohammad (1976), Nalluchinnappan et al. (1982) and Yoo et al. (1986).

Length-frequency analyses are limited in tropical pearl oysters by the lack of distinct spawning seasons. Bimodal length-frequency histograms caused by heavy predation of juveniles were misinterpreted as discrete annual cohorts by Galtsoff (1933) and Pandya (1975). Samples of cultured *P. fucata martensii* were taken periodically by Yoo et al. (1986), but growth was compared only from final sizes (i.e., 6.1 cm over 17 months, versus 4.1 cm over 19 months).

Growth ring formation can be correlated with length-frequency analysis and tagging studies to obtain estimates of age and intervals between ring formation. Shell samples from the wild can then reveal growth histories. The formation of annual rings in *P. fucata* was observed in cultured *P. fucata* juveniles in the Gulf of Kutch (Pandya 1976; Gokhale et al. 1954 and Narayanan and Michael 1968, both in Chellam 1978)). The single ring formed over summer was related to retarded growth associated with diminished feeding or spawning (Pandya 1976). Growth rings are also found in *P. maxima* from Western Australia (R. Dybdahl, pers. comm.), but not *P. fucata* from the Gulf of Mannar (Chellam 1978), *P. margaritifera* from the Cook Islands (Sims 1990) or in other Australasian pearl oysters (Hynd 1960b).

### **Factors Affecting Growth**

Growth is closely related to ambient temperatures, but other seasonal factors such as reproductive periodicity and food availability are also

important (Pandya 1976; Nasr 1984). Numaguchi and Tanaka (1986b) showed a consistent rise in the  $K'$  value where  $K' = 100[(\ln L_2 - \ln L_1)t^{-1}]$  for spat of *P. fucata martensii* from 12 to 26°C and then a near constant  $K'$  value of 3.5 from 26 to 32°C with a sharp decline in the  $K'$  value at higher temperatures. The growth rate was closely correlated to the heart rate.

Temperature also affects the thickness of nacre layers (Chellam et al. 1987b). Pearls are harvested during the winter in Japan, when the deposition of thinner nacre layers produces better color and luster (Matsui 1958; T. Fuji, pers. comm.).

Salinity was shown by Numaguchi and Tanaka (1986a) to alter the growth rate of *P. fucata martensii* spat. The fastest heartbeat occurred between 26.5 and 30.3 ppt salinity and the optimum salinity between 22.7 and 37.9 ppt.

Spawning stress reduces the growth of pearl oysters as it does with a variety of other bivalves (Orton 1928; Quayle 1952). Nasr (1984) noted a decreased rate of growth in mature *P. margaritifera* that coincided with the spawning season.

As mentioned previously, the current flow and the turbidity of the water are also important in determining growth rates.

Growth rates under culture conditions depend on the environmental conditions at the farm site (e.g., Nalluchinnappan et al. 1982; Yoo et al. 1986). Depth and stress factors are also important. The depth of culture can be used to regulate temperature, light and to a lesser extent turbidity. The minimum depth required for the rearing of *P. fucata* is 5 m, which is favorable for the production of pearls of a pinkish color although the growth rate is slow (Alagarwami 1970). An ideal depth for the culture site of *P. fucata* is between 15 and 20 m. The stress factors that may be controlled by the culturist are handling, crowding, fouling, predators and parasites. These are reviewed below.

## **Mortality**

### **Predation**

Juvenile pearl oysters are particularly vulnerable to predation. Hornell (1914a, 1914b) attributed the highly cyclic nature of the Indian and Sri Lankan pearl oyster fisheries to the changing predator/prey balance. The most important

predatory fish were *Balistes* sp., *Tetradon* sp., *Lethrinus* sp., *Serranus* sp. and various species of sharks and rays. Predators other than fish include octopus, starfish, crabs and a variety of predatory gastropods. *Murex virgineus* (= *Chicoreus virgineus*) is a voracious predator of *P. fucata* in the natural beds (Chellam et al. 1983). *M. anguliferus* (= *C. virgineus*) was again noted as the worst predator in unprotected *P. margaritifera* culture beds in the Red Sea (Crossland 1957). *M. ramosus* (= *C. ramosus*) has also been implicated (Rao and Rao 1974; Dharmaraj et al. 1987a).

The prominent growth processes in juvenile *Pinctada* spp. (and some other lamellibranchs) offer a form of passive defense from predators (Crossland 1911). Species with large growth processes (notably *P. margaritifera* and *P. maxima*) have a longer period of initial, rapid growth and attain greater maximum sizes. In trials, *M. ramosus* (= *C. ramosus*) attacked only those *P. margaritifera* which were stunted and did not possess growth processes (Crossland 1911). Species without spinous growth processes attain their maximum sizes quickly and rapidly thicken their shells; such species will only survive in protected sites (Crossland 1911).

Fish are not a problem in a culture operation if the pearl oysters are covered. *P. maxima* and *P. margaritifera* have an escape size of between 80 and 100 mm beyond which mortality due to predation is low (Crossland 1957). Spat transferred directly from collectors into uncovered trays in Donganab Bay, Sudan, incurred mortalities of up to 50% (Reed 1962).

Crabs and, to a greater extent, gastropods may inflict serious mortality in cultured stocks. Certain species of crabs enter the culture enclosures as larvae and are therefore difficult to control. For example, the portunid, *Charybdis* spp. destroyed entire cages of *P. fucata* stock in Vizhinjam Bay, India (Appukuttan 1987).

Gastropods of the family Ranellidae (= Cymatidae) are regarded as serious pests in the outgrowing stage of hatchery culture of *P. margaritifera* and *P. maxima* in Okinawa and other tropical areas (M. Yamaguchi, pers. comm.). They can be difficult to control due to their extremely long planktonic larval stages (Scheltema 1971). It is believed that settlement is induced by the presence of a host (H. Govan, pers. comm.) and therefore farms provide ideal settlement areas. A method that can be employed for the control of predators that settle, as larvae, onto juvenile oys-

ters is to allow limited access of other predatory species into the culture container. Open topped fine mesh bags can be used to cover pearl oyster spat which limit access to the spat by larger predators such as fish but allow small predators and grazers inside. Various culturists believe that a reduced mortality rate of spat is incurred by using this method. *Cymatium cingulatum* preys on *Pinctada* spp. in India (Chellam et al. 1983, 1987; Dharmaraj et al. 1987a; Nayar and Mahadevan 1987). *C. muricinum*, *C. aquatile*, *C. nicobaricum* and *C. pileare* have all been observed to prey on the smaller *Pinctada* species in laboratory experiments in the Solomon Islands (H. Govan, pers. comm.). Ranellid and Muricid gastropods are not thought to present a problem to pearl oysters once the escape size has been reached and if off-bottom culture techniques are used.

### **Fouling and Boring**

Fouling and boring organisms infest natural and cultured stocks of pearl oysters. Their removal is both tedious and expensive but failure to do so can result in high mortalities and a reduced value of the shell.

The types of foulers encountered and their relative abundance vary both geographically and temporally. The fouling organisms of most importance are barnacles, bryzoans, molluscs and tunicates. Rock oysters, edible oysters, sponges, isopods and algae will also foul both the oysters and the cages (Saville-Kent 1890; Cahn 1949; Alagarwami and Chellam 1976; Mohammad 1976; Dharmaraj and Chellam 1983; Appukuttan 1987; Dharmaraj et al. 1987a). Barnacles, oysters and other molluscs can physically prevent the pearl oysters from opening by growing along the hinge line and even cementing the valves together. Alagarwami and Chellam (1976) found a close relationship between barnacle load and *P. fucata* mortality. Excessive fouling results in reduced growth rates (Alagarwami and Chellam 1976; Mohammad 1976). This is due to a combination of reduced plankton availability, caused by a decrease in water flow and increased competition and because the extra loading on the valves of the pearl oyster is likely to decrease the filtration efficiency.

Boring polychaetes, sponges, molluscs and isopods cause considerable damage to the shells of pearl oysters. Sponges such as *Cliona celata* can

infest the whole shell, usually starting from the umbo. The shell can become friable and more susceptible to other borers (Alagarswami and Chellam 1976). Molluscs of *Lithophaga* sp. and *Martesia* sp. can make large holes in the shell. Isopods make shallow grooves on the shell surface, damaging the periostracal and prismatic layers. Polychaetes bore through the periostracum and on into the prismatic and nacreous layers. The rate of infection can be very high and the damage substantial. Where the nacre is damaged as with sponges and polychaetes, there is a diversion of energy needed to cover the area of damage caused by the organisms. This can result in a reduced growth rate of both pearls and pearl oysters and if the degree of infection is severe can weaken the oyster so much that it dies. Mohammad (1972) found an inverse correlation ( $r_s = -0.903$ ) between the percentage of infestation by polychaetes and weight of the pearl yield per oyster. The shell value will also be reduced by borers. *P. margaritifera* shell cultured in the Red Sea suffered a 25% reduction in value due to infestation by *Lithophaga* and *Polydora* (Crossland 1957). In Sudan, 50% of natural shell from below 18.3 m (10 fathoms) was unsaleable (Reed 1962, 1966). There is a predictable increase in the percentage of infection of pearl oysters by borers with age (Mohammad 1972; Velayudhan 1983).

Control of fouling organisms and their impact on pearl oysters is discussed later in the section on fouling control (p. 34).

### ***Parasites and Pathogens***

Early research on the parasites and pathogens of pearl oysters focused on the presence of parasitic cestodes, nematodes and trematodes (Shiple and Hornell 1904; Mizumoto 1964; Berry and Cannon 1981). Their impacts on the hosts are not well documented. Cestode larvae were considered beneficial in the production of the larger and finer pearls of the Indian and Sri Lankan pearl fishery (Shiple and Hornell 1904; Hornell 1922). Cheng (1967) stated that encapsulation may be a defensive mechanism against invading foreign bodies.

Oysters with internal parasitic infestation are always discarded prior to pearl nucleus implantation, as the likelihood of nucleus rejection or mortality is high.

Mass mortalities have affected pearl culture in Japan, French Polynesia, Australia and the Red Sea. Nevertheless, causative agents are difficult to identify and therefore prove their pathogenicity. Anomalous structures in histological preparations are difficult to identify (Wolf and Sprague 1978; Pass and Perkins 1985). Disease-causing organisms are from among the marine bacteria, protistans and viruses, with poorly described etiology and complex biochemical identification tests. Comprehensive series of host-challenge trials are needed to differentiate between primary pathogens, secondary infections and saprophytes, and benign commensal organisms (Nasr 1982; Coeroli 1983; Dybdahl and Pass 1985; Goggin and Lester 1987; Pass et al. 1987). Extensive host tissue damage supposedly from protistan parasites in *P. maxima* (Wolf and Sprague 1978) was considered by Pass and Perkins (1985) to be necrotic autolysis. The "protistan parasites" were probably normal constituents of the digestive cells. However, similar bodies were considered to have been the cause of a mass mortality of *P. margaritifera* in the Red Sea (Nasr 1982). The true cause of these mass mortalities is therefore unclear.

Overcrowding of pearl oysters (Crossland 1957; Hynd, unpublished report, in Potter 1984; Lowe 1986), build-up of detritus under farms (Crossland 1957; Reed 1985; Lowe 1986), lower water temperatures and confinement during transshipment (Dybdahl and Pass 1985; Pass et al. 1987) have all been associated with epidemics. Pass et al. (1987) found that the majority of diseased *P. maxima* oysters were infected with the marine bacteria *Vibrio harveyi*. This was shown experimentally to induce disease similar to that seen in the field. Mortalities can be controlled through improved handling and holding practices, better water circulation, decreased densities and improved hygiene on farms and during transshipment, and avoiding transshipments during colder months (Pass et al. 1987).

Diseases of cultured *P. margaritifera* in French Polynesia have been spread by shipments between lagoons (Reed 1985) and have recently appeared in wild stocks of *P. margaritifera* and other bivalves (*P. maculata*, *Tridacna maxima*, *Arca ventricosa*, and *Spondylus varius*: Coeroli 1983; M. Coeroli, pers. comm.).

## CULTURE OF PEARL OYSTERS

Hauti et al. (1987, 1988, in Preston 1990) divided pearl culture operations into the three categories: collection, ongrowing and pearl culture. A fourth category, hatchery production, should now be included in this classification. Ongrowing, although usually carried out for the purpose of pearl production, with the shell and meat being a by-product can take place solely for the sale of the shells (e.g., in Sudan). At each stage there are a number of different culture methods in use, the choice of which depends upon the species cultured and the location or environment.

The different phases of production permit a degree of specialization by farmers and allow people of different income brackets and different levels of technical expertise to become involved in the pearl oyster cultivation process. For example in three French Polynesian atolls during 1986 and 1987, 129 farmers were involved in collection, 60 in ongrowing and 40 in pearl culture, with some farmers involved at each stage (Preston 1990).

### Hatchery Culture

Hatchery culture of pearl oysters is becoming more widespread and assuming greater significance to the industry. Hatcheries now provide a large proportion of the *P. fucata martensii* in Japan. India has hatchery production of *P. fucata*. *P. margaritifera* has presented more of a problem, due to feed (Tanaka et al. 1970b, 1970c, 1970d; Kakazu et al. 1971) and broodstock problems (Millous 1977, 1980; Coeroli et al. 1984). Hatcheries have been slow to produce large numbers of juvenile *P. maxima* but this is now beginning to happen (R. Rose, pers. comm.). Private firms are producing *P. maxima*, *P. margaritifera* and *Pteria penguin* in the Ryukyus Islands, *P. maxima* and *P. margaritifera* in the Philippines and *P. maxima* in Australia and Indonesia, but production is still limited. A government hatchery in French Polynesia is now producing up to 300,000 *P. margaritifera* spat per year (M. Coeroli, pers.

comm.). Hatchery work for *P. margaritifera* and *P. maxima* involves commercial or national interests and the results are largely proprietary.

Hatchery production allows selective breeding for desirable traits and assures a continual supply of juveniles. There has been a lot of industry resistance to hatchery production of *P. maxima* in Australia, mainly due to fears of an oversupply of pearls reducing the market value but also because of a scepticism concerning the quality of hatchery produced oysters (L. Joll, R. Rose, N. Paspaley, pers. comm.).

### Spawning

Temperature variation is the main means of spawning induction. There is usually no need for forced maturation or other stimuli (Tanaka et al. 1970a; Alagarswami et al. 1983a). Natural spawning usually begins with the male spawning first. The sperm suspension stimulates the female to spawn (Alagarswami et al. 1983b). When broodstock are taken from the wild, as with *P. maxima* in Australia, spawning regularly takes place in the transport tanks of the fishing vessel or on arrival at the hatchery. This is believed to be both stress and temperature induced (Tranter 1958d; Wada 1976b; Rose et al. 1990). With conditioned broodstock, thermal induction for *Pteria penguin*, *P. maxima* and *P. margaritifera* consists of alternately raising the temperature 5-6°C from the ambient sea temperature leaving the oysters in the water for 30 minutes and then putting them back into the ambient temperature seawater again for another 30 minutes. This process is continued until spawning occurs (Tanaka et al. 1970a). *P. fucata* has been spawned in India successfully by raising the temperature 6.5°C from 28.5 to 35°C (Alagarswami et al. 1983a). Ripe *P. fucata martensii* will spawn within 2-3 hours after being taken from the sea (20°C) and placed into tanks at 24°C.

Spawning induction has also been achieved by chemical induction and with filtered ultraviolet

sterilized seawater (Rose and Baker 1989). Chemicals used include ammonium hydroxide, hydrogen peroxide, neutral potassium salts, tris buffer, sodium hydroxide and a mixture of sodium hydroxide and tris buffer (Alagarwami et al. 1983a). *P. fucata* showed poor response to hydrogen peroxide and a pH specific response to tris (pH = 9.0 -9.5) (Alagarwami 1983a). Sodium hydroxide (pH 9.5) resulted in limited spawnings, and ammonium hydroxide when injected into the foot or the adductor muscle gave a spawning response of 48.1%. Japanese hatcheries producing *P. fucata martensii* often use ammoniated seawater for artificial fertilization of stripped gonads (Wada 1942, 1947; Kuwatani 1965c; Tanaka et al. 1970a; Tanaka and Kumeta 1981) so that the quality of the parent shells can be observed. However, temperature induced spawnings usually result in higher fertilization rates, more normally developed larvae and better overall survival rates (Tanaka et al. 1970a; Tanaka and Kumeta 1981; Rose and Baker 1989; Rose et al. 1990).

Broodstock conditioning outside of the normal spawning seasons can also be temperature induced. *P. fucata* broodstock may be kept in spawning condition if fed a mixed algal diet supplemented with cornflour and maintained at a temperature between 25 and 28°C (Alagarwami et al. 1987). Gonad maturation of *P. fucata martensii* can take place out of season by raising the water temperature from ambient up to 18-24°C. A three-week period at temperatures of 20-22°C fully matures the gonad (Hayashi and Seko 1986). Rose et al. (1986) failed to condition *P. maxima*, despite trying a variety of techniques and relied on broodstock brought directly from the fishing grounds.

### Larval Rearing

Techniques for larval rearing have been described for *P. fucata* by Alagarwami et al. (1983b, 1983c, 1987); for *P. fucata martensii* by Wada (1973) and Hayashi and Seko (1986); for *P. margaritifera* by Setoguchi (1964, 1966), Tanaka et al. (1970a, 1970b, 1970c, 1970d), Kakazu et al. (1971) and Alagarwami et al. (1989) and for *P. maxima* by Wada (1953a, 1953b), Minaur (1969), Tanaka and Kumeta (1981), Rose et al. (1986) and Rose and Baker (1989). Larval rearing methods for *Pteria penguin* are similar to those used for *P. maxima* and *P. margaritifera* (M. Muramatsu and J. Fukushima, pers. comm.).

The techniques are basically the same as for most bivalve larvae, relying on good feed quality and quantity, clean water and low larval densities. Larval rearing protocols for each species are given in Table 6.

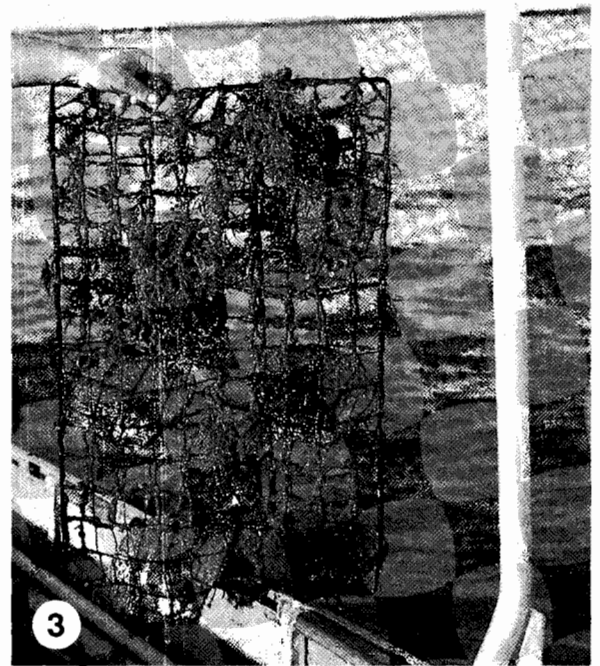
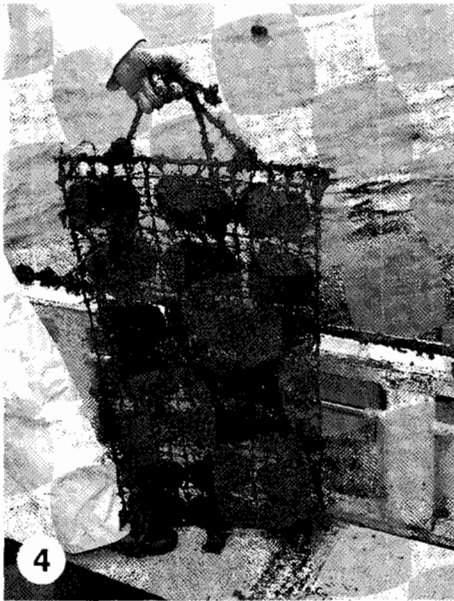
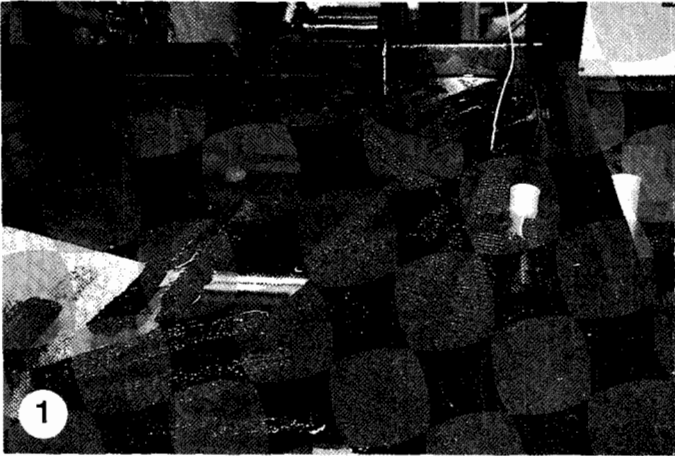
### Larval Feeding

The lipid content of microalgal food is critical to bivalve larvae (Brown et al. 1989; Volkman 1989). Variable growth in *P. fucata martensii* larvae was probably due to differences between algal batches (Wada 1973). Poor survival of *P. margaritifera* larvae was attributed to specific feed requirements (Tanaka et al. 1970b; Kakazu et al. 1971). Glycogen, lipid, sterol and protein levels in microalgae and pearl oysters provide direct measures of food value and assimilation efficiency (Desai et al. 1979; Teshima et al. 1987; Yamaguchi 1987). A range of algal species ensures a balanced diet. Five species of microalgae are routinely used in commercial hatcheries for all four commercial species of pearl oysters (M. Gervis, pers. obs.) from spawning until settlement. Tanaka and Inoha (1970) questioned the use of *Pavlova lutheri* as a food for tropical pearl oysters due to the potential change in its physiology and morbidity rate when removed from its growing medium at 20°C and put into the larval culture tanks at 28-30°C. However, this alga continues to be used commercially.

Larval stocking density appears optimum at less than 10 larvae per ml. Rose and Baker (1989) advocated an initial stocking density of less than 5 per ml for *P. maxima*. Filtration of the water is recommended to 5 µm or less and 1 µm filters are most often used in Japanese hatcheries. Low bacterial counts in the feed (less than  $1.5 \times 10^5$  cells per ml (Rose and Baker 1989) and regular water changes are recommended. Antibiotics are not used routinely in flowthrough systems, but only for the treatment of bacterial infestations.

Grading is carried out routinely in Japanese hatcheries. Hayashi and Seko (1986) graded on day 8, 13 and 18. Growth does not appear to be affected by culling but postsettlement survival is enhanced (Alagarwami et al. 1987). Gentle aeration is used in Japanese hatcheries for all species, but for mixing rather than gas exchange (as in the culture of other bivalve larvae). Alagarwami et al. (1987) showed that aeration reduced growth and survival of larvae, but it is possible that the airflow was too vigorous.

## Aspects of Pearl Oyster Culture

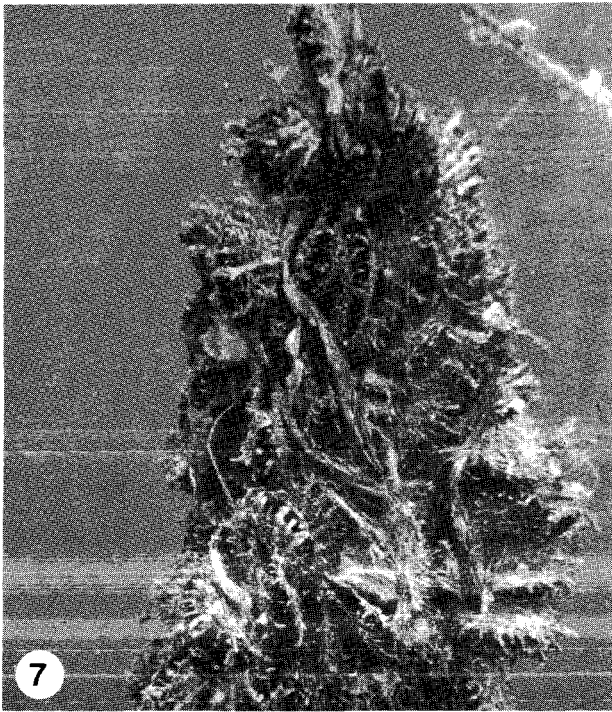


1. Plastic film rolls for spat settlement in larval rearing tank.
2. Mesh covered frame for hanging spat on a plastic film.
3. *P. maxima* in a pocket net.
4. *P. fucata martensii* in a sandwich net.
5. Raft and longline culture in Gokasho Bay, Mie Prefecture, Japan.
6. Automated oyster cleaning machine.

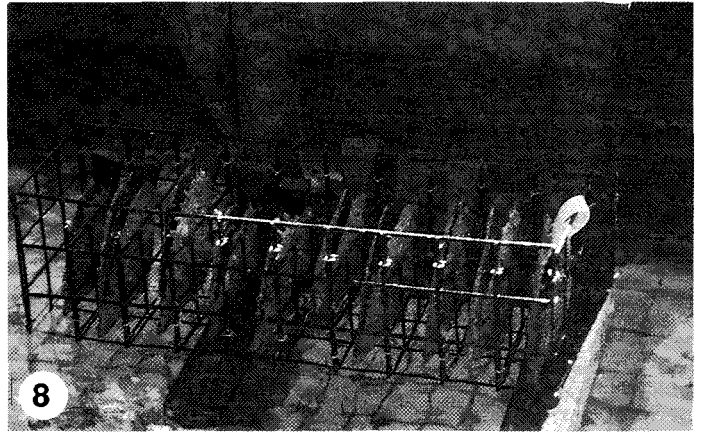


Photo credit: Plates 1 to 6 - M.H. Gervis.

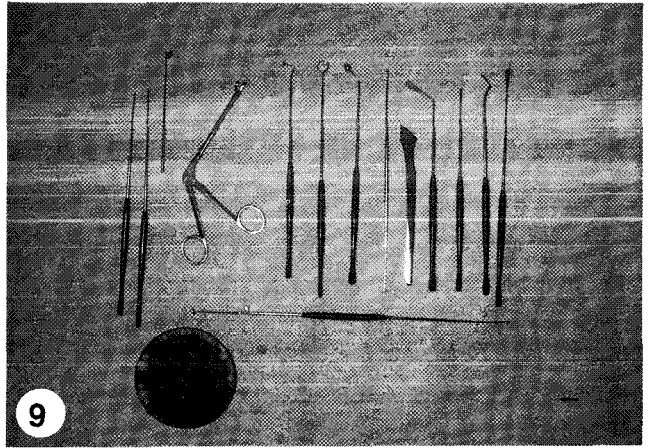




7



8

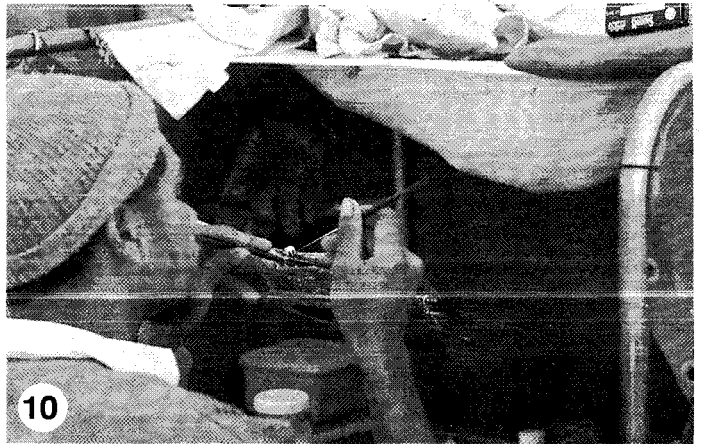


9

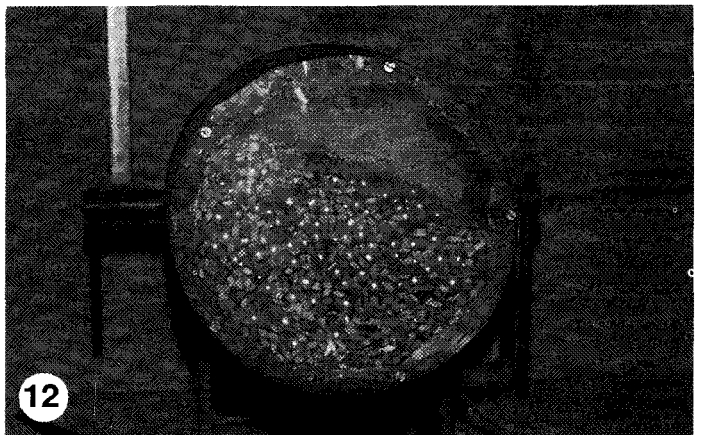
- 7. A heavy spatfall of *P. margaritifera* on a rope collector.
- 8. *P. maxima* wedged open prior to nuclei implantation.
- 9. Tools used in the pearl implant procedure with a selection of nuclei.
- 10. *P. maxima* being implanted with a nucleus.
- 11. Pearl *in situ*.
- 12. Cleaning of pearls with bamboo chips.



11



10



12

Photo credits: Plate 7 - N.A. Sims, Plates 8 to 12 - R. Scoones.



Table 6. A summary of various larval rearing protocols for the three cultured *Pinctada* species.

Species	<i>P. fucata martensii</i> <sup>1</sup>	<i>P. fucata</i> <sup>2</sup>	<i>P. maxima</i> <sup>3</sup>	<i>P. margaritifera</i> <sup>4</sup>
Algal food tested (larvae to settlement)	Pav, T. Iso, C. gra., Chl. (Pav, C.cal., Chl.) <sup>7</sup>	T. Iso, Pav, Chro, Dier,	C. cal., C. gra., T. Iso Tet.+ Nan.- optional	T. Iso - a Pav. - a (Pav, Dun.) <sup>5</sup> (C. calc, Cyc.) <sup>6</sup> - b Rho. <sup>5</sup> - c
Algal food Postsettlement	Nanno., Tet., Pav.,	Mixed algæ esp. <i>Chaetoceros</i> sp.	C. gra., T. Iso., Tet., Pav., Dun.	T. Iso., Ske., Nit.,
Algal density day	300 - 8000 (cells/ind/day) 1 - 20	80 - 350 µl <sup>-1</sup> (8) 1 - 32 <sup>8</sup>	100 - 25000 (cells/ind/day) 1 - 30	5 - 10 µl <sup>-1</sup> 1 - 28 (< 5 = optimum)
Stocking density larvae ml <sup>-1</sup>	12 - 4	1 - 10	10 - 1	1 - (Unknown)
Filtration	1 µm	2 µm and UV light	5 or 1 µm	Sand filter and cotton wool
Water change	Flow through	Every two days	Daily	Daily
Survival rate	30 to 38% to days 30-35	-	.0004 to .01% to days 15-28	6.3% 28

## Notes

Except where otherwise specified, the protocol followed for each species was according to the reference indicated by the superscript adjacent to the species concerned.

- indicates no data available.

## References

- 1 - Hayashi and Seko (1986)
  - 2 - Alagarwami et al. (1987)
  - 3 - Rose and Baker (1989)
  - 4 - Alagarwami et al. (1989)
  - 5 - Kakazu et al. (1971)
  - 6 - Tanaka et al. (1970)
  - 7 - Wada (1973)
  - 8 - Alagarwami et al. (1983c)
- a - *Isochrysis* was preferred to *Pavlova* and used as the standard food.  
b and c - species were rejected by *P. margaritifera* in these trials.

## Algal species

Ske. - *Skelotenema* sp.

Nit - *Nitzschia* sp.

Pav - *Pavlova lutheri*

T. Iso - Tahitian *Isochrysis galbana*

C. gra - *Chaetoceros gracilis*

C. cal - *Chaetoceros calcitrans*

Chl - *Chlorella* sp.

Tet - *Tetraselmis* sp.

Nan - *Nannochloris* sp.

Cyc. - *Cyclotella nana*

Rhod - *Rhodomonas clavus*

Dier - *Dicrateria* sp.

Chro - *Chromulina* sp.

## Settlement

Larvae settle onto a variety of substrates. *P. margaritifera* clearly prefers dark surfaces. Black or dark blue spat collectors produce best yields in the wild and are also commonly used in hatcheries for all species (Coeroli 1983; Coeroli et al. 1984; Cabral et al. 1985). Black rearing vessels produced better survival and settlement rates than blue or white in hatchery-bred *P. fucata* (Alagarwami et al. 1987), but the ubiquitous clear polycarbonate tanks of Japanese hatcheries are also satisfactory

(see Table 1). *P. fucata martensii* is commonly settled onto small pieces of 55% shade mesh (25 x 40 cm) left in rolls on the water surface. These can then be hung directly onto growout frames when transferred to the sea (see Plate 1, p. 24 and section on juvenile on-growing, p. 30). Panel nets filled with lengths of 1-mm polyethylene twine and hung in the rearing tanks also give good results and ensure collection throughout the water column. Spat remaining in the rearing tanks after the initial collection has occurred are concentrated into boxes filled with the shade mesh rolls to

induce settlement (M. Gervis, pers. obs.). Spat will also settle on the tank sides and base (Alagarwami et al. 1989; Rose and Baker 1989). Rose and Baker (1989) also used plates of dark glass and plastic, monofilament fishing line and plastic netting. A preference for darker and older, used materials was shown. Greater settlement densities towards the base of the tanks was observed. *Pteria penguin* settles onto short braids of 3-mm polyethylene rope woven through 8-mm polyethylene rope (M. Gervis, pers. obs.)

Settlement induction in *P. maxima* was tested using adrenalin and L-Dopa with minimal success (Rose and Baker 1989); the use of other chemical agents is not reported. In any event, the provision of a suitable substrate appears to be sufficient to induce settlement.

## Genetics and Hatchery Production

Hatchery production provides opportunities for selective breeding for growth, color and shape. Production of triploids and single sex cohorts may also enhance growth rates.

Selective breeding trials for *P. fucata* have been carried out for a number of characteristics and are summarized by Velayudhan (1987). Selective breeding of *P. fucata martensii* can increase the percentage of shells with white coloration in the nacre from 20 to 80% by the third generation (Wada 1986b). The white coloration of the prismatic layer is also inherited and is under the control of a recessive gene (Wada 1983; Wada and Komaru 1990). Both the nacre and the prismatic layer help to determine the eventual pearl color. But the nacre color of the mantle donor is the greatest influence on final pearl color (Wada 1985).

Shell width and shell convexity are readily inheritable in *P. fucata martensii* (Wada 1984, 1986c). Heritability of the shell size was estimated to be 0.22-0.25 (Wada 1985, in Velayudhan 1987). The heritability of larval shell length from sire components was estimated to be 0.335 on day 4 or 5, 0.181 on day 10 and 0.078 on day 15 (Wada 1989), which are lower values than those reported for other bivalve species.

Velayudhan (1987) reported the successful crossing of *P. fucata* and *P. sugillata* producing viable spat.

Some mortalities in hatchery-bred *P. fucata martensii* have been related to inbreeding depression. Decreased heterozygosity due to genetic drift or selection pressures in the hatchery could be

avoided by the use of large numbers of parents (Wada 1986a). Outbred strains showed both better survival rates and faster growth (Wada 1984, 1987). Natural selection pressures and isolation can also cause decreased heterozygosity among wild populations of *P. fucata*, *P. chemnitzii* (Li et al. 1985) and *P. margaritifera* (Blanc 1983; Blanc et al. 1985).

The use of triploidy could offer special advantages in pearl oysters as a sterile animal may prove easier to seed for pearls (Wada et al. 1989). Triploidy induced by chemical and temperature shocks in *P. fucata martensii* zygotes resulted in heavy larval mortalities (Wada et al. 1989; Uchimura et al. 1989). Unfortunately, the triploid pearl oysters were not all sterile; several released viable sperm and eggs, which were aneuploid (more or less than the diploid chromosome number). This poses a serious risk in the use of triploids, as release of eggs or sperm amongst the natural population could degenerate the natural stock (Wada and Komaru 1991).

Karyotyping of eight species of Pteriidae: *Pteria penguin*, *P. maculata*, *P. albina*, *P. maxima*, *P. margaritifera* (Wada and Komaru 1985), *P. fucata* (Komaru and Wada 1985) and *P. imbricata* (Wada 1978), showed all to have 28 diploid chromosomes.

## Spat Collection

The spat of most pearl oyster species will settle onto artificial materials placed into the sea (spat collectors). Materials used in spat collectors vary, depending on the species to be collected, the location and the traditional methods of collection for that area. Vakily (1989) set out the following criteria for evaluating an appropriate spat collection material:

- a) efficiency as a spat collector;
- b) local availability of material;
- c) durability of material; and
- d) initial cost of investment.

Successful spat collection depends upon the materials used, location, season and depth at which the collector is deployed. Collection sites can be very localized as a result of current flows and eddy formations (Sims 1990). Timing for the laying of the spat collectors can be critical. Poor timing can result in the collection of either smaller unwanted *Pinctada* species (Crossland 1957) or other fouling organisms. Spat collection for *P.*

*margaritifera* in many areas of the Philippines has not been successful due to the high productivity of the water and the extent to which the spat collectors become fouled (J. Branellec, pers. comm.). Spat collectors for both *P. margaritifera* and *P. fucata martensii* are usually set from the surface down to 3 m. Densest settlement occurs 2-3 m (Shirai 1970; Coeroli et al. 1984). Settlement of *P. albina albina* occurs at the sea surface, with *Pteria penguin* being found on the outside, rather than the inside of collectors. *P. maxima* has greatest settlement below 3 m (R. Scoones, pers. comm.).

Spat are left on the collectors for up to six months before being transferred to juvenile ongrowing systems.

Collector materials are most commonly suspended from longlines or rafts but individually buoyed structures can also be used. The most popular types of materials now in use are cedar sprigs in Japan and *Pemphis acidula* branches or "flower type" collectors in French Polynesia and the Cook Islands (Table 7). The "flower type" collector consists of a 50 x 25 cm strip of either Hyzex film (a black plastic sheet) or shade mesh

(55-65% shade is commonest), folded concertina fashion and tied at the midpoint. If the width is greater than 25-30 cm, the spat will tend to become dislodged and fall off and the spat settled towards the center of the collector will not get sufficient water flow. The use of protective grills or meshes around the collector is becoming less common as fouling of the mesh reduces water flow. Exceptional settlement may be up to 1,000 spat per collector but with an average of 30 on the flower type collectors. Fig. 5 shows a schematic arrangement of collectors on a longline. Split bamboo collectors (1 m x 1 m x 4 m) are still in use in Donganab Bay on the Sudanese coast (Crossland 1957; Gideiri 1983; Rahma and Newkirk 1987).

Hatchery trials have shown preferential settlement on dark materials or on the underside of materials, indicating negative phototaxy at settlement (Alagarswami et al. 1983c; R. Rose, pers. comm.). Spat settlement in hatcheries is carried out by placing either shade mesh, nylon rope or panel nets (see Fig. 6) stuffed with nylon twine into the water (see Plate 1 and refer to the section on hatchery production, p. 27).

Table 7. Materials and equipment that have been used for the collection of pearl oyster spat.

Location	Species	Material	Reference
Japan	<i>P. martensii</i>	Cedar sprigs Mollusc shells Old fish nets	Shirai (1970)
India	<i>P. fucata</i>	Oyster baskets Nylon mesh Nylon frills	Victor et al. (1987) Nayar et al. (1978) Achari (1980)
Cook Islands	<i>P. margaritifera</i>	Hyzex film, <i>Pemphis acidula</i> , black & blue polyethylene & polypropylene rope	Passfield (1989)
French Polynesia		Netron tube Shade mesh <i>Pemphis acidula</i> sprigs	Coeroli et al. (1984)
Sudan		Wooden (deal) boards Split bamboo	Crossland (1957)
Papua New Guinea		Nylon rope	Lock (1982)
Mexico	<i>P. m. mazatlantica</i>	Hatcher boxes*	Baqueiro and Castagna (1988)

\* - Wooden frame boxes 3 x 2 x 1 m with galvanized wire mesh sides, a solid wooden lid for shade and flotation and inner compartments stuffed with shells, branches or other cultch, fifty adult oysters were placed in one of the compartments (Baqueiro and Castagna 1988).

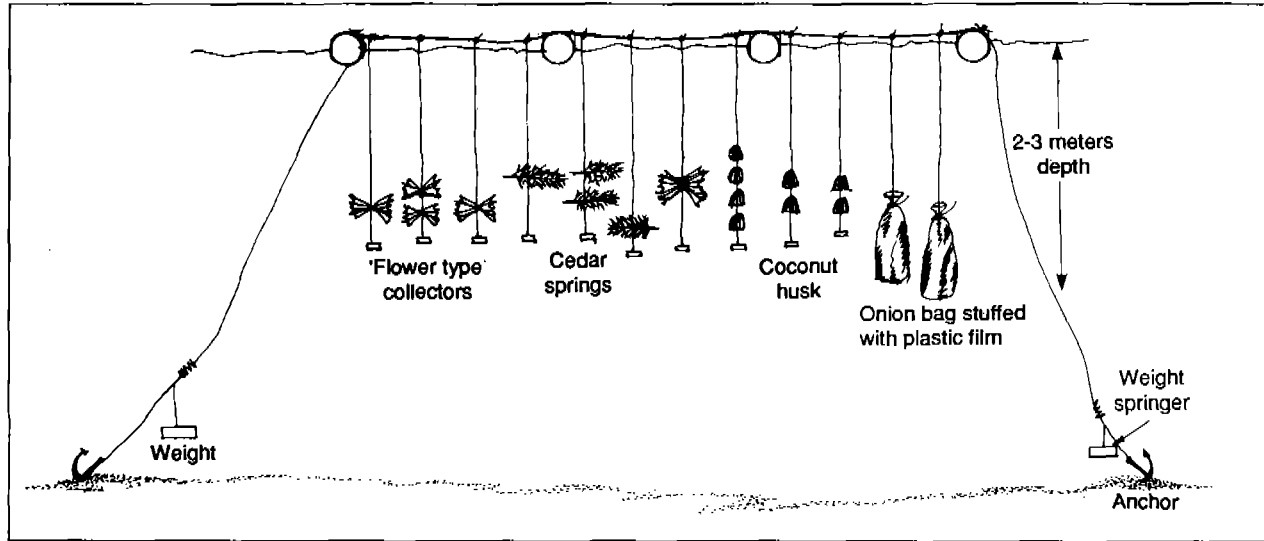


Fig. 5. Diagram of part of a longline showing some materials that may be used for *Pinctada* spat collection.

Spat of *P. fucata martensii* and *P. margaritifera* are collected commercially on a large scale and those of *P. fucata* and *Pteria penguin* to a limited extent. Spat collection trials for *P. maxima* spat in Australia have not yet proved to be commercially viable (R. Scoones, pers. comm.). If there is a shortfall of collected spat of *P. margaritifera* in French Polynesia or the Cook Islands, it is made up by collecting adults from wild stocks. In Japan, the culture stock of *P. fucata martensii* is either hatchery-reared or taken on collectors; the percentage of collected spat will vary depending upon annual differences in natural spatfall and hatchery production. Natural spatfall of *P. fucata martensii* no longer takes place in many traditional areas; deterioration in water quality is a possible cause of this phenomenon. Spat collection in India has had limited success while *P. margaritifera* has been collected commercially in the Sudan since 1957.

### Nursery Rearing

Juvenile pearl oysters are thin-shelled and therefore highly vulnerable to predation. As mortalities of juveniles can be high, nursery rearing is a critical stage.

Nursery rearing begins when spat are either removed from collectors, if large enough (greater than 10 mm DVM), or left on the collector material and put into a rearing container. Either

lantern nets, circle nets or pearl nets are used (Fig. 6). These nets are cheap, readily available and easy to store. The frame is usually made from galvanized or plastic-coated wire and covered by polyethylene netting. The pearl nets have a standard range of mesh sizes from 3 to 30 mm while the circle and lantern nets range from 9- to 30-mm mesh size. In India, pearl nets are enclosed in a fishnet bag of 10-mm mesh size to protect the finer mesh net from damage by fish and crabs (Chellam et al. 1987b). Plastic perforated baskets are also used until the oysters reach 20 mm.

The nets are held on or suspended from a variety of different structures. Surface or subsurface longlines may be used, trestle frames can be set up on the seabed or surface rafts can be employed.

Hatchery-grown juveniles are put into the sea on the materials on which they settled in the hatchery tanks. Lengths of the material are stretched onto frames (Plate 2, p. 24) and then hung from a longline or raft in areas of calm water. The protective mesh screen covering is changed regularly, increasing the mesh size as the spat grow.

As the spat grow, the density is reduced and the cage mesh size increased (Table 8). This reduces fouling and increases the flow of water through the cage, thereby ensuring an adequate food supply to all of the oysters. The oysters are continually graded during the first two years to ensure optimum growth conditions. No localized

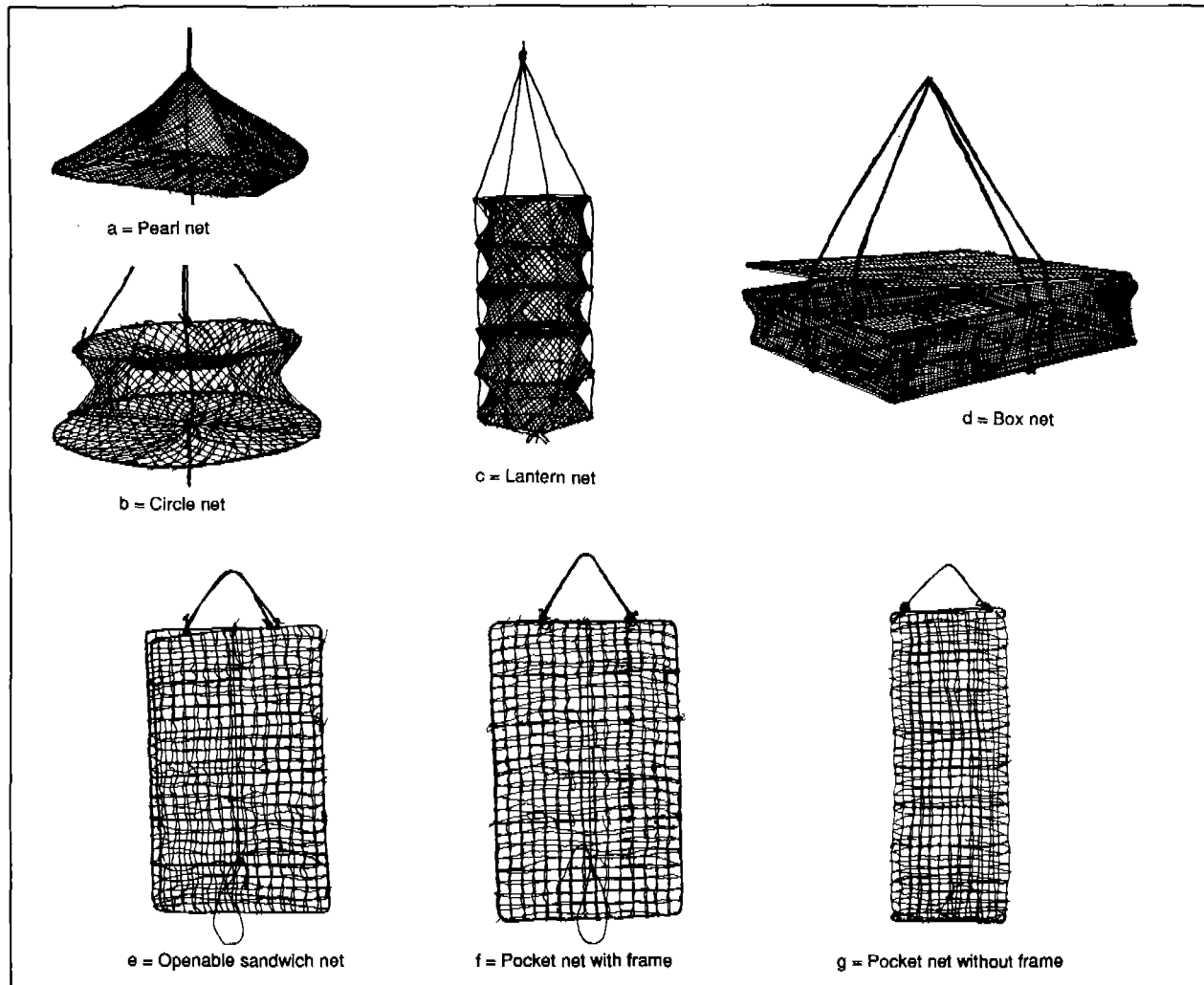


Fig. 6. A variety of nets used in the on-growing of pearl oysters.

crowding should be allowed to take place otherwise shell growth can be deformed and growth rates retarded as a result of competition for both food and space.

In the Sudan where the pearl oysters are reared purely for shell (Gideiri 1983), the nursery is constructed *in situ* with the bamboo slat collectors being placed on layers of weldmesh, inside a chicken wire cage. The structure is set up on teak poles in the sea (Gideiri 1983) or single layers may be buoyed up on a longline (Rahma and Newkirk 1987). The floating system was found to give increased growth rates and easier handling. In the experimental juvenile on-growing of *P. maxima* in Australia both lantern nets and pearl nets were used. A current driven upweller "FLUPSY" system, as used in oyster culture in the UK, was also successfully trialled (Anon. 1985).

## Ongrowing

Ongrowing systems are used once the pearl oysters have outgrown the nursery rearing baskets or once they are large enough to be seeded for pearls. The development of systems appropriate to the on-growing of pearl oysters has improved as the mother stock has become rarer due to the effects of overfishing and the value or potential value of the stock has increased. In Ago Bay, Japan, the stock used to be scattered over the seabed in demarcated areas. Such "banking" is still used as a temporary measure in many areas. In Penrhyn, Cook Islands, banks are used to hoard undersized oysters until they reach the minimum legal size for sale as shell. This is now rare in Manihiki (Sims 1990). In Australia, oysters are banked after they have been collected and

Table 8. Change in rearing structure, mesh size and stocking density with increasing oyster (*P. margaritifera* and *P. fucata*) size (adapted from Coeroli et al. 1984 and Chellam et al. 1987b).

Oyster size (mm)	Rearing structure used		Mesh size (mm)	Density per structure	
	<i>P. margaritifera</i> <sup>1</sup>	<i>P. fucata</i> <sup>2</sup>		<i>P. margaritifera</i>	<i>P. fucata</i>
2-7	boxes		3	200	
7-10	lantern nets	lantern nets	4.5	100	
10-15	"	or plastic buckets	4.5	50	
15-20	"	"	9	50	
20-30	"	box cages	9	40	
30-40	"	"	9	30	125
40-50	"	"	9	20	100
50-70	panel nets	"	20	30	75
70-100	"		30	3	
>100	(panel nets or ear hung on ropes)	-	40 10/string	12	-

<sup>1</sup>From Coeroli et al. (1984).

<sup>2</sup>From Chellam et al. (1987b).

before the pearl nuclei are implanted (M. Buckley, pers. comm.). Off bottom culture allows for better control of the stock and avoids many of the predators.

Ongrowing stock may be held in one of three types of panel or pocket nets (Fig. 6).

The sandwich-type panel net, often used for *P. fucata*, has two frames that shut on each other. The oysters are sandwiched between rows, ventral side up, with 6-8 in a row. The oysters are arranged so that they overlap, allowing the byssus to attach to the adjacent oyster (Alagarswami 1970).

The framed pocket net is used for all species but especially for *P. maxima* and *P. margaritifera*. It consists of a single wire frame with new mesh divided into a series of pockets which hold the pearl oysters. These are closed using twine or plastic coated wire garden ties.

The pocket net without frame (which is now used extensively for *P. fucata martensii*) consists of a net with 5-10 rows of pockets stretched between a top and bottom hanger.

Baskets or box cages (Fig. 6) are often used for holding *P. fucata martensii* after implanting with nuclei. Box cages (400 x 400 x 100 mm frame with a lid) covered with 2-mm synthetic twine mesh are used in India for the culture of *P. fucata* (Chellam et al. 1987b). The mesh size used will depend on the size of the oyster being cultured. In general, box cages are more difficult to manage for older stock (> 50 mm) than panel nets or pocket nets as the stock are liable to form clusters which can lead to stunting or death. They are also more prone to fouling and reduced water flow. They cannot be used with mechanical

cleaners and are therefore not recommended in areas of high labor costs.

Ear hanging is a method that has been adopted from the Japanese scallop industry and is used extensively in French Polynesia and the Cook Islands for *P. margaritifera*. Once the DVM is greater than 90 mm (AQUACOP 1982), they are drilled through the posterior ear and hung in pairs on a downline (Fig. 8). This method is also employed for the culture of *Pteria penguin* in the Ryukus Islands where the shells are drilled at the hinge and hung singly.

The containers or lines are then hung from a longline, raft or trestle either singly or one beneath another. Initially, oysters were hung from rafts in bamboo baskets or wire baskets. Nowadays, longlines, rafts and trestles are used with a variety of different containers. The choice between longlines, fencelines, rafts and trestles depends on:

- a) current speed;
- b) water depth;
- c) capital cost;
- d) operational costs;
- e) exposure to wind and waves;
- f) ease of operation;
- g) need for direct access from land;
- h) security considerations; and
- i) tidal variation.

### Rafts

Rafts are rigid floating platforms either anchored or moored to fixed structures such as jetties (Fig. 7).

Raft culture is best practiced in sheltered areas where wind and wave exposure is low.

Offshore raft culture is feasible but the costs of building and securing such raft systems is higher than the alternatives. In areas of strong currents, such as Northwestern Australia, raft culture has been superseded by longline culture.

The advantages of raft systems are that they are easy to work on, there is no need for diving to inspect the stock and they are therefore cheaper to service. They may also be land-based if placed next to jetties and this has particular advantages during the period of pearl nucleus implantations, obviating the need for a special vessel or platform. The initial costs can be very low but this can be offset by high maintenance costs if materials of low durability such as bamboo are used.

The disadvantages of rafts compared with trestles and longlines are that the stock is held at a high density, which has implications in both the spread of disease and the availability of nutrients. The rafts flotation is more complex to maintain than a longline system. It is also harder to clean the stock with mechanical cleaning systems.

Raft construction varies between areas. Styrofoam or polystyrene floats inside plastic coverings, metal drums, plastic containers, fiberglass reinforced plastic floats or bamboo are commonly used for buoyancy. Bamboo can fulfill the dual role of float and platform but does not have great durability and is often better used as a platform material in conjunction with other types of floats. Metal drums must be sealed and thoroughly cleaned and treated with an antirust paint (red lead primer) and then painted with an anticorrosion paint (Cheong and Lee 1984). Rafts usually have four or six floats each of 300-l capacity. The increase in weight due to oyster growth or fouling is relatively small and extra buoyancy units therefore do not have to be added over the culture period.

Teak poles are used in India for platform construction (Alagarwami 1987) while cypress, cedar or bamboo are used in Japan. Steel pipes have been tried but their use is not yet common (Mizumoto 1976). The poles are usually lashed together to increase flexibility.

Raft sizes vary. The industry has mainly adopted the traditional Japanese raft (Fig. 7) which measures 6.4 x 5.5 m and has four 0.6 x 1.05 m styrofoam floats. Planking is often put on top. The platforms have 100 hanging points. In relatively exposed conditions, as in India, single rafts are moored with two anchors (Chellam et al. 1987b). In the protected bays of Japan up to 10 rafts are moored together.

### ***Longlines and Fencelines***

The longline system consists of a buoyed main line, made taut by an anchor assembly (Fig. 5). A springer system is often used to take up the tidal slack. The low profile, streamlined longline system presents minimal resistance to weather and sea (Vakily 1989). Johns and Hickman (1985, in Vakily 1989), listed a number of advantages of the longline system over rafts, namely:

- a) construction, set-up and transport are much easier to accomplish;
- b) more economic use of flotation capacity as all buoys provided are available to support the crop, rather than the platform and the stock;
- c) convenient adjustment of the required flotation in accordance with crop weight; and
- d) the smoother movement of longlines in rough weather results in less wear on anchor lines shackles and thimbles.

Surface longline systems are used in Japan for *P. fucata martensii* and *Pteria penguin* culture and extensively in Australia for the culture of *P. maxima*. In areas of high current speeds, such as Broome in Western Australia, raft culture has been superseded by longline systems. Longline systems in Japan are often arranged in blocks of lines, usually 80 m x 48 m, composed of 12 lines 4 m apart. The lines are kept equidistant by ropes running across the width of the block at 16-m intervals, joined to the mainlines using 18-mm rope rings. Buoys are spaced at 4-m intervals with two buoys at the end of each line (22 buoys per line). The corners of these longline blocks are anchored at three points and anchors run from every mainline and each of the four spacing lines. Springer weights are used on all anchor lines. Panel nets, baskets or downlines are usually spaced 1 m apart, varying with the weight of the stock.

In French Polynesia and the Cook Islands, subsurface longline systems have largely replaced trestle culture of *P. margaritifera*. Subsurface longlines provide greater security, present less hazard to navigation, and result in less movement from wave action being transmitted to the oysters.

Fencelines are essentially longlines in which the buoys have been replaced by posts driven into the seabed. The panels on downlines are hung on the line raised off the seabed. Fenceline operations can be used in very exposed locations and significantly increase the number of possible oyster culture sites. The capital cost of a fenceline operation

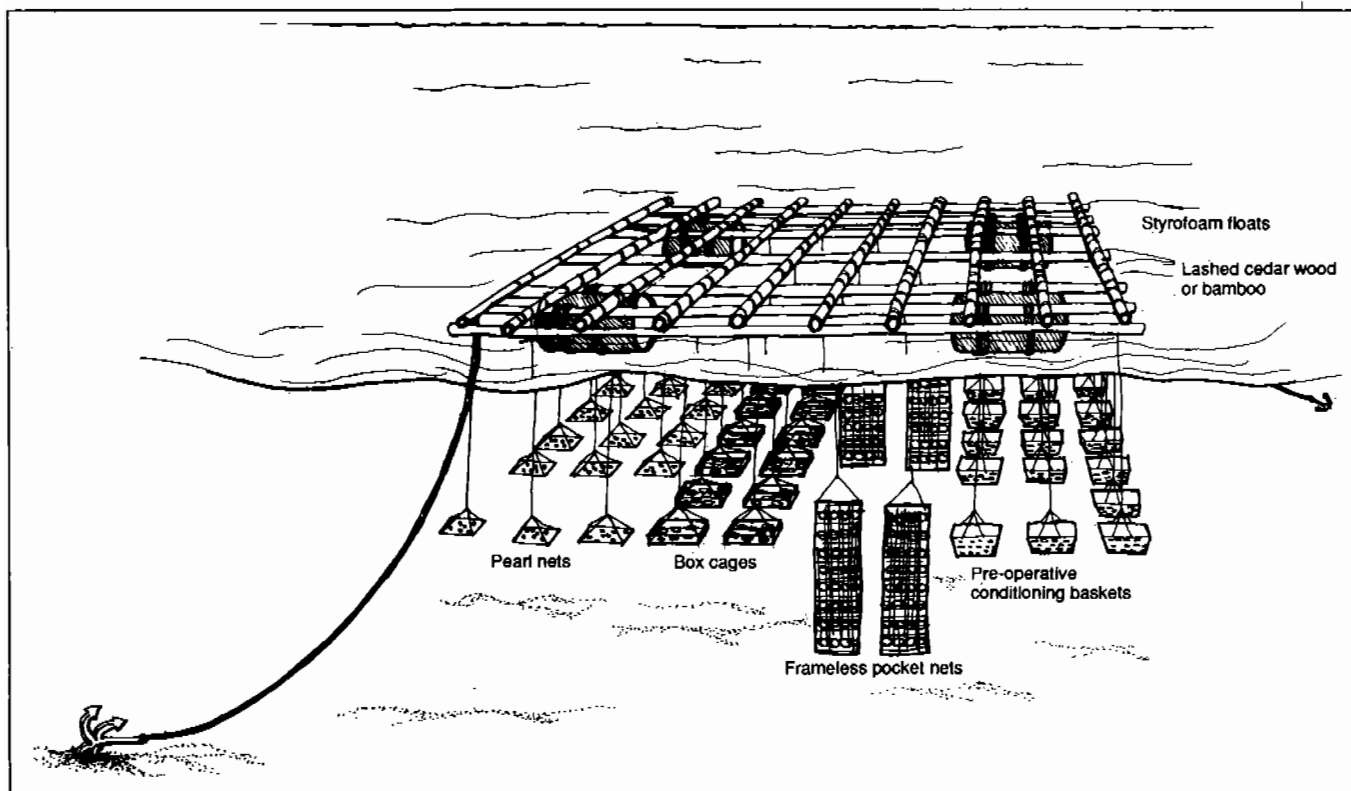


Fig. 7. Typical construction and use of a single raft as used in the pearl culture industry.

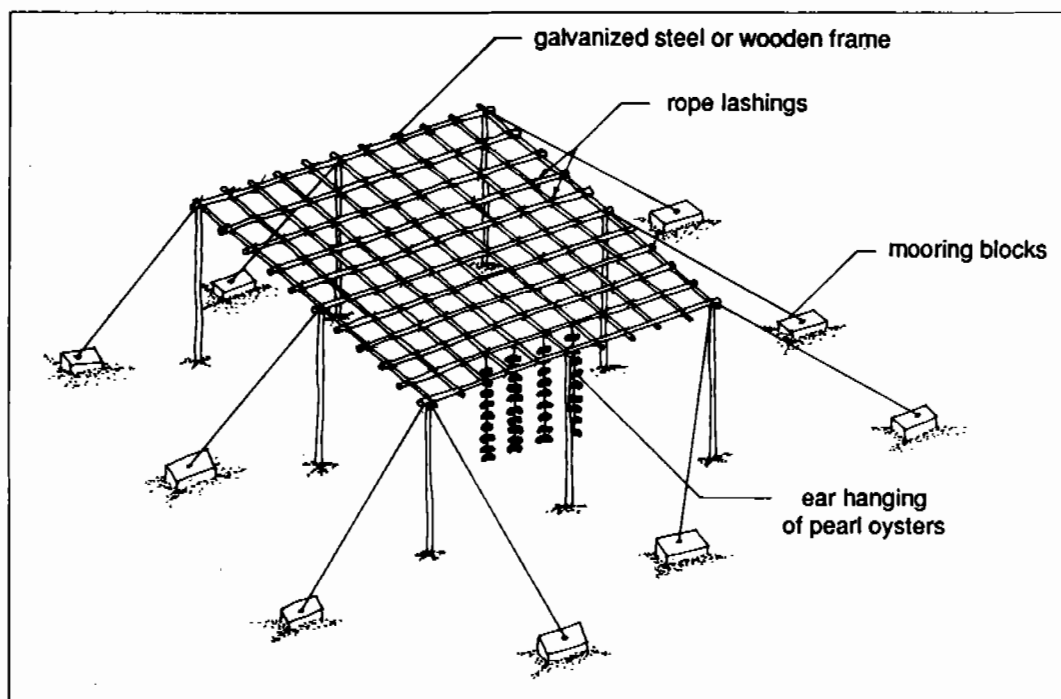


Fig. 8. Trestle culture system as used for *P. margaritifera* culture in French Polynesia.



is less than that of a surface line because there is no need for floats, but they are difficult and expensive to service as they require the use of divers. Mechanical cleaning machines cannot easily be used with this system.

### **Trestles**

The trestle system consists of a rigid structure fixed to the seabed onto which the rearing containers or lines can be placed or hung (Fig. 8). This system was used extensively in French Polynesia and the Cook Islands for *P. margaritifera* (Coeroli et al. 1984). It has been used for *P. maxima* in Australia and for *P. margaritifera* culture in the Sudan. It is still used throughout Polynesia for holding oysters to recover after seeding.

Like the fenceline system, it has the advantages of being a low cost, low maintenance system not exposed to adverse weather conditions. Being subsurface, it is also reasonably secure. Construction is relatively simple consisting of lashed poles, galvanized or PVC pipes. If pipes are used, such a construction can be very long lasting. The disadvantages of the system are similar in many respects to those encountered in rafts: the stock is much more concentrated with greater chance of disease transfer, restricted food availability and detrital build-up on the underlying substrate. It also needs to be serviced by divers.

### **Fouling Control**

The control of fouling and boring organisms is critical for promoting good growth and quality of both the pearl and pearl oyster. Regularity of cleaning depends on the degree of fouling. Many farms in Australia work on a six-week cycle (M. Buckley, pers. comm.). Japanese farmers clean more frequently in the summer than the winter.

Routine cleaning involves the mechanical or manual scrubbing of the oyster with stiff brushes, or the use of high pressure water jets to remove epiphytic algae, bivalve spat, barnacles, ascidians and tunicates. This is usually done at the surface but sometimes this process is carried out by divers. The use of panel and pocket nets on longline systems is ideal for ease of cleaning when used in conjunction with the mechanical cleaners. These machines consist of high pressure water jets spraying from above and beneath the pearl oysters

at pressures up to 2,000 psi, the pressure adjusted according to the age of the shell and the degree of fouling.

Boring organisms, such as polychaetes, sponges or molluscs often cannot be removed by mechanical or manual scrubbing. Other control measures are available. If the infection is not too serious, a knife or meat cleaver can be used to remove the organisms.

Saturated salt solutions are still commonly used for the removal of polychaetes in Japan (Shirai 1970). The oysters are submerged in the brine for between 15 and 40 minutes. The tentacular movements of the polychaetes are observed and when all have died the oysters are rinsed off with fresh water and returned to the culture site. This method has the advantage of being easy, cheap and relatively quick.

Brushing of *P. fucata* with 1% formalin and then exposing the oysters to the air for 15 minutes was completely effective in killing all sponges and *Martesia* sp. and 87.7% effective in killing the polychaetes. Mortality of 0.1, 2.3 and 0.8% was observed in the first, second and third month, respectively, following the experiment. Exposure for 30 minutes after brushing caused 10-12.5% of the oysters to die, while exposure for one hour caused 100% oyster mortality (Velayudhan 1983).

Immersion of pearl oysters in fresh water for 6- to 10-hour periods killed all the *Polydora* and *Cirrulatus* sp. while the oysters remained in good condition.

Methods used on edible oysters may also be appropriate to pearl oysters, but pearl oysters are much more sensitive to air exposure than edible oysters. Alternative methods include the use of DDT, BHC and compounds of chlorine, copper sulfate, ferric chloride, pentachlorophenol, mercury, arsenate, blueing agents, naphthalene and other antifouling agents (Arakawa 1980, in Chellam et al. 1987b).

### **Pearl Culture**

Pearl culture involves the implantation, into the gonad, of one or more spherical nuclei together with a piece of mantle tissue. The mantle tissue eventually grows around the nucleus and secretes nacreous deposits to form a pearl. The implantation techniques are still largely proprietary secrets of the Japanese. Most implants are conducted by Japanese technicians. Training of

pearl technicians now also occurs in India and French Polynesia and the Australian government requires the industry to build up a core of non-Japanese operators. This is difficult to enforce. The cost of training technicians is substantial. There is an opportunity cost in the loss of revenue from either poor quality or rejected pearls during the training period. The actual cost of the mother shells to be implanted is also high (estimated to be A\$12-16 per shell: Rose and Baker 1989). Given the strict quotas allowed in the Australian pearl oyster industry, it is easy to understand the reluctance to train new personnel.

Japanese technicians are trained using *P. fucata martensii*, a smaller and less valuable pearl oyster. Training begins by using small nuclei and slowly increasing the nucleus size with experience and success. The training period can take from between a few months to two years (Alagarwami 1970). The implantation procedure for *P. maxima* and *P. margaritifera* is more difficult. To become proficient in the implantation procedure for these species thousands of oysters need to be implanted.

Scientific studies on the nucleus implantation procedure are all reported in Japanese (through the National Pearl Research Laboratory, now the National Research Institute of Aquaculture: Aoki 1956, 1959a, 1959b; Yamaguchi 1959, 1961, 1964; Machii 1961). Alagarwami (1970) and George (1969) also describe the implant operation. The procedure varies slightly for each of the three commercial species of *Pinctada*. The common elements for all species are described below.

### **Preoperative Phase**

The implantation is carried out on mature oysters. For *P. fucata*, the DVM should be greater than 50 mm; for *P. margaritifera*, >100 mm; and for *P. maxima*, >120 mm. The preoperative conditioning phase has been described by Japanese researchers in the following way. The pearl oyster undergoes a general weakening process for 28-40 days, during which time the musculature and gonad epithelium degenerate. This process induces the pearl oysters to spawn and ensures that it is sufficiently weak not to reject the inserted nucleus or nuclei. For *P. fucata martensii*, the oysters are crowded into baskets with a small mesh aperture. Poor water flow and low availability of oxygen and food initiates the stress. They are then lowered to a greater depth than normal which again reduces

the food available. By raising and lowering the cage, the oysters can be induced to spawn due to both temperature shock and stress conditions (S. Funakoshi, pers. comm.). Alternatively, the oysters are moved to the open sea where the change in temperature and salinity induce spawning, or a full oyster basket is lowered onto the seabed and left there (Alagarwami 1970).

Spawning during conditioning is important as loose organic material can cause flaws and a blue coloration in cultured pearls. The oysters spawn during the first 7 to 10 days of conditioning. Over the next 7 to 10 days any remaining sperm or oocytes are resorbed. A further 7 to 10 days ensures that any gametes produced during the previous 14 to 20 days are also resorbed. The final 7-10 day period is to ensure that the musculature has weakened sufficiently for the implant to take place (S. Funakoshi, pers. comm.).

Pearl oysters undergoing this treatment have a shorter postoperative recovery period, resuming normal physiological activity levels faster than oysters which have not undergone the treatment (Uemoto 1961). The pearl layer is also established earlier in pretreated animals (Uemoto 1961).

The weakening process is considered to be critical to the success of the implant operation. If the animal is too weak or the muscle epithelium of the gonad too thin, then the inserted nucleus will be rejected through the gonad wall. Approximately 70% of all rejected nuclei are lost in this manner. If the oyster is too strong, the nucleus may be rejected by muscular contraction, most often coming out through the incision. This accounts for the remaining 30% (S. Funakoshi, pers. comm.).

### **Spherical Pearl Implant Operation**

Pearl nucleus implantation takes place during the cooler months, preferably when the temperature is on the rise. There is usually a three- to four-month period during the year when this can take place. For *P. maxima*, the operation is performed best when the temperature is less than 26°C (M. Buckley, pers. comm.).

The conditioned oysters are brought to the operating platform or laboratory where they are cleaned and pegged open. Often they will gape on being removed from water, at which point hardwood wedges are immediately inserted in the anteroventral corner to hold the valves apart. If

gaping does not occur, shell openers (flat-bladed reverse pliers, see Fig. 9) are put into the posteroventral corner and the valves slightly opened to insert a wedge. Any oysters with parasite infestations are discarded.

The mantle grafts are usually prepared concurrently with this procedure. The choice of mantle graft is critical to the eventual quality of the pearl. The graft is taken from a healthy, unconditioned oyster with desirable nacre color, as the donor tissue influences the color of the nacre of the recipient pearl (Wada 1985). The mantle is cut from each valve of the donor, cleaned of mucus and the thicker outer edge trimmed. The desired portion of mantle is that which is most actively laying down nacre. This is at the junction of the nacreous and non-nacreous border. A single strip, usually between 50-75 mm long and 3-5 mm wide, is cut from each mantle. This is cut into smaller squares and washed with a solution of eosin in seawater, or other antiseptics or antibiotics. The piece that is used and the area that it originated from in the donor oyster are known to influence the growth and color of the resulting pearl.

In an effort to guarantee donor mantle suitability, tissue culture of the outer mantle epithelial cells is being attempted in Japan. The immediate priority is to develop an appropriate cell culture

medium (A. Komaru and M. Muramatsu, pers. comm.). Once the proliferation of epithelial cells is achieved, appropriate methods for implant, such as the injection of a cell suspension or the creation of a backing piece such as collagen for a single cell layer need to be investigated.

The nuclei that are used originate from freshwater mussels of the genera *Tritogonia*, *Quadrula*, *Pleurobema*, *Amblema* and *Meglonais* (Unionidae) (Alagarswami 1970). These shells have massive nacreous layers with a hardness, specific gravity and thermal conductivity that make them particularly suitable for use as pearl nuclei. The Unionids originate from the United States and usually produce beads up to 13.5 mm (Roberts and Rose 1989). This is limiting when trying to produce very large pearls (16-20 mm) from *P. maxima*. Alternatives are currently being investigated and these include shells of giant clams, *Tridacna* spp., and pearl shells. The nuclei are produced by cutting the shell into cubes and then rounding off the edges on a lapping machine. A very smooth finish is achieved by polishing them in hydrochloric acid.

The seeding operation begins with a wedged oyster being placed into the oyster stand (Fig. 9). A shell opener is inserted in the posteroventral corner of the oyster and the wedge is removed from the opposite side. Using a spatula the mantle and gills are pushed aside to keep them out of the way while performing the operation. The foot is then retracted slightly, using the retractor probe, in order both to immobilize it and to raise the gonad slightly, making the area for incision more exposed. A slit is made into the gonad and a probe used to make a path through to the area in which the operator wants the nucleus to lie. The prepared mantle is then inserted followed by a nucleus. If more than one nucleus is to be used, as with *P. fucata* in which two or three nuclei are commonly inserted, they are put into position next. The shell side epithelium must be placed against the nucleus otherwise only a "keshi" or seed pearls will be formed. At the end of the implantation, the incision is simply smoothed closed and the shell opener removed before returning the oyster to the water.

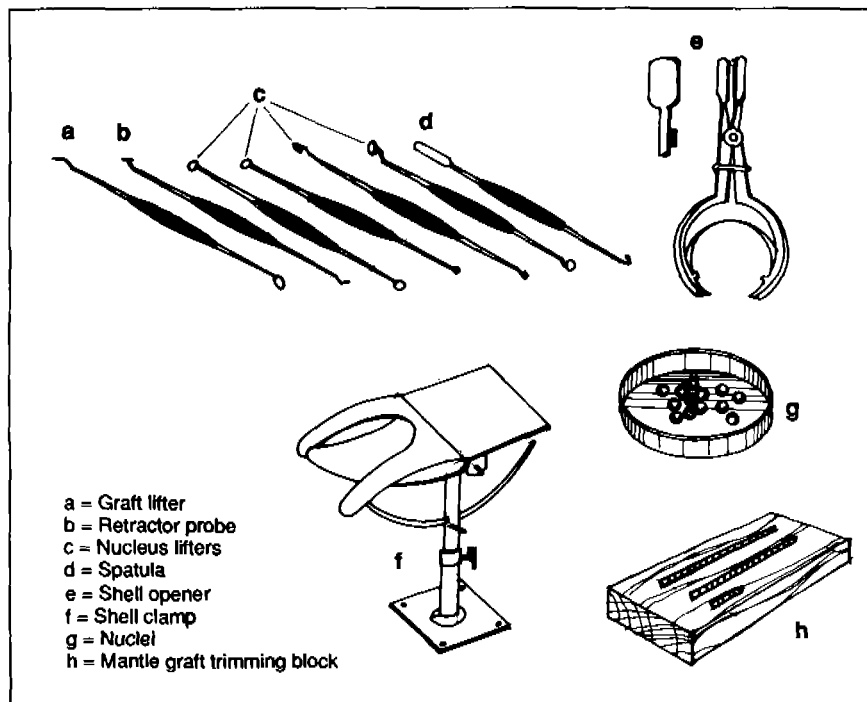


Fig. 9. A selection of tools used during the procedure to implant pearl nuclei into the mother oyster.

The mortality of implanted oysters indicates that further work on the use of muscle relaxants and the neurophysiology of the muscle relaxation process deserves consideration.

### ***Pearl Formation***

Kawakami (1952a, 1952b) describes the sequence of events after the mantle graft and nucleus have been inserted in *P. fucata*. After insertion, the mantle tissue starts to spread around the nucleus in a cup shape. After three days, a degenerative process takes place in the inner epidermis and the mesodermal tissue, leaving the outer epidermis to complete the pearl sac by itself. This completely envelopes the nucleus within seven days. The secretion of the periostracal material begins after 15 days, following the thickening of the epithelium. The prismatic layer is then laid down. After approximately 40 days, the nacreous layer begins to be secreted. The deposition process can sometimes become disorganized, with the stratification becoming partially or totally disrupted, resulting in flawed pearls. The identification of the hormonal control systems controlling shell production and the isolation of the shell growth stimulating hormone are future research priorities.

### ***Postoperative Care***

After implantation, the oysters are treated with great care in order to minimize nucleus rejection. The oysters are usually moved to very calm, deep water, with little current to minimize disturbance and keep the metabolic rate low. After 203 weeks, when the pearl sac should have formed, they are moved to their normal growout area. In Australia, implanted *P. maxima* are laid horizontally in a panel net with the umbo up for the first seven days after operation. They are then turned so that they lie on the opposite valve. This turning procedure takes place every two days initially, but gradually decreases until it is once in each neap tide. The whole process lasts for two months and supposedly increases the likelihood of obtaining perfectly spherical pearls. The actual value of this process is debatable and it may just be the legacy of a conservative industry with no one individual or company wanting to risk enough nucleated oysters to run a proper control group. This is an area of the pearl culture process that merits more investigation.

*P. fucata* are usually operated on once in their lives but commonly more than one nucleus is inserted. *P. maxima* and *P. margaritifera* can be implanted for whole spherical pearls up to four times, although three is more common (M. Buckley, pers. comm.). In reseeded operations, the pearl formed from the previous operation is carefully removed and evaluated. If it is a good quality pearl, a nucleus the size of the pearl that has just been harvested is inserted. If the harvested pearl is of poor quality or shape, the oyster is either used in half pearl operations or killed for the shell. There is no need to condition the oysters prior to reoperation and no need to use a piece of mantle as the pearl sac is already fully formed.

Oysters operated on by each technician are kept separate so that the success rate of the technician can be monitored by the farmers. The first indication comes about three months after the operation when the shells are x-rayed. Those that have rejected their nuclei are harvested, or kept for reimplanting. The technician is evaluated at final harvest according to the per cent success and quality of the pearls harvested.

### ***Pearl Culture Period***

Pearls are usually cultured between 18 months and 3.5 years after being implanted. A medium quality pearl is estimated to have 1,000 layers of nacre on it, resulting in a nacre thickness of 0.4-0.5 mm (Hollyer 1984). In the industry, 2 mm after 2 years is the accepted norm. The daily deposition of nacre can vary from zero to seven layers per day, with the main factors determining the rate of deposition being the water temperature and the physiology of the individual oyster (Hollyer 1984). The culture period necessary is also dependent on the size of the nucleus. In Ago Bay, Japan, most farmers produce very small pearls using 2-5 mm nuclei cultured for only six months. This is mainly due to the pollution in the area resulting in slower nacre growth and a higher mortality rate. Operations take place in spring, with harvest in autumn to prevent overwintering mortality.

### ***Harvesting***

Harvesting usually takes place when the water temperatures are lowest. As the nacre layers are at their thinnest, then the best luster is achieved on the pearls. If the oyster is cut open,

Table 9. Japanese pearl imports from the major marine pearl producing countries for 1988 and 1989 (modified from Tanaka 1990b).

Country	Year	Nonprocessed		Stringed		Total	
		kg	US\$ (x 1,000)	kg	US\$ (x 1,000)	kg	US\$ (x 1,000)
Australia	88	1,068.45	45,209	0.99	163	1,069.44	45,372
	89	1,217.34	70,438	9.97	913	1,227.44	71,351
Fr. Polynesia	88	312.89	24,912		54	312.89	24,965
	89	498.63	40,759	4.99	692	503.62	41,451
Indonesia	88	339.98	8,454	0.00	0	339.98	8,454
	89	516.00	11,557	0.00	0	516.00	11,557
Philippines	88	81.40	5,096	-	6	81.40	5,075
	89	70.42	3,790	-	0	70.42	3,790
India	88	26.60	132	46.34	64	272.94	196
	89	31.52	604	307.18	2,085	338.70	2,689
Formosa	88	55.47	55	207.28	2,041	325.75	2,096
	89	331.23	159	768.94	114	1,100.17	273
Thailand	88	36.80	589	4.99	786	41.79	1,375
	89	15.98	682	-	103	15.98	785
Malaysia	88	299.02	1,369	-	52	299.02	1,421
	89	25.83	701	0.00	0	25.83	701
Myanmar	88	0.65	75	0.00	0	0.65	75
	89	27.15	629	0.00	0	27.15	629
Cook Islands	88	0.00	0	0.00	0	0.00	0
	89	11.40	444	0.00	0	11.40	444

the adductor muscle is removed either for later sale or for the crew. The other shucked meat is mixed with lime and rotated in a barrel with wooden blades to macerate the meat. The heavier pearls fall to the bottom of the barrel (Alagarswami 1970). The pearls are then washed with neutral soap and water, dried and sorted. Reject pearls (about 30%) are used in pharmaceuticals, misshapen pearls (about 40%) are marketed for use in various pieces of jewelry and the gem quality pearls (30%) are sorted according to size, color and luster. They are then sold individually or on strings. The "necklace" (i.e., graduated) value of a single pearl of the right size and color to complete a series is far more valuable than if sold separately. Japanese pearl producers often bleach, bake or dye their pearls to produce white, pink, blue or dark brown (near-black) colors (Ward 1985).

### Half Pearl Production

*Pteria penguin* is used solely for the production of half "mabe" pearls producing "rainbow" half

pearls of a very high quality. *P. maxima* and *P. margaritifera* are also be used for half pearls. Half pearls are less valuable than round pearls but may be a useful source of income for firms without the services of seeding technicians. Oysters that have rejected their nuclei or are too old or unsuitable for further spherical pearl operations will often be seeded for half pearls.

Half pearl nuclei are most often hemispherical but may be irregular shapes (e.g., teardrops, hearts, etc.). The nuclei, usually plastic, are glued to the outer nacreous area of the valves. Waterproof, fast-drying glues are used, such as cyanoacrylates. Up to seven half pearl nuclei may produce greater returns per oyster than if four or more nuclei are used (M. Muramatsu, pers. comm.). As the mantle immediately covers the half pearl nucleus, shell deposition takes place in the normal manner and the shells are harvested after a year or more. The half pearls are drilled from the shell using a hole saw and in most cases the nuclei removed before sale. The nuclei may then be reused.

## MARKETING AND ECONOMICS

There are three products from the larger cultured pearl oysters: pearls, shell and meat (*Pteria penguin* and *P. fucata* do not have saleable shells). The pearls are very valuable, easily transported and nonperishable, making them an ideal product even for remote areas without well-developed infrastructures. Pearl shell is also a valuable product and nonperishable, but it is bulkier to transport. The meat is highly prized by both local consumers and by the Japanese market, but it is a perishable product and must be processed (freezing, drying or smoking) if it is to be transported a long distance to market. The meat is often given to farm workers where the quantities produced are not sufficient for processing. This product could be used more profitably. Major farming operations and Japanese producers sell the meat fresh to the sushi trade. *Pteria penguin* meat is particularly prized for this. Companies outside of Japan usually produce a sundried product ("kaibashira") which currently sells for US\$120/kg (N. Paspaley, pers. comm.).

Shell is marketed mainly for use as buttons but with the higher quality shell being used in inlay work (a specialty of Korean and Japanese furniture makers) and shell-based accessories, such as earrings, necklaces and brooches (Philipson 1989; McElroy 1990). Shell is sold whole and is graded according to quality. Japan and South Korea are the major importers of pearl shells with the imported tonnage to both of these countries varying from 1,000 to 1,500 t·year<sup>-1</sup> between 1980 and 1987 (Philipson 1989). The production of plastic buttons after 1945 depressed the shell market initially. Shell buttons are still used on high quality clothing, however, and the apparent "demise" of the market has been overstated. Demand has recently increased.

Shell prices fluctuate rapidly according to supply. In 1990, wholesale prices were US\$8.00/kg for A grade *P. margaritifera* shell and US\$11.00/kg for A grade *P. maxima* shell (McElroy 1990) up from US\$3.00/kg for A grade *P. margaritifera* in 1987 (Philipson 1989). Large pearl farms may

stockpile shell until prices rise and then sell. The resulting flooded market may temporarily lower prices. The larger farms may then buy shell from smaller producers who often rely on shell sales for cash flow. This destabilizing cycle can then be repeated. Rahma and Newkirk (1987) estimated that Sudanese production of *P. margaritifera* for shell alone was economically viable when shell prices are greater than US\$0.75/kg at a discount rate of 40% or less. The internal rate of return was calculated as 45.7% with a 40% mortality from collected spat to harvest, falling to 11.1% with an 80% mortality rate.

Shell may also be used in "cottage industries" at source, creating local employment and income. Polished and carved pearl shell products for the tourist market and items of this nature are produced in the Philippines, Indonesia, Fiji, French Polynesia and the Cook Islands.

Pearls, both half and whole, are usually graded on the farms and sold at auctions either in the producing country or elsewhere, most often Japan. The value of pearls is based on a combination of size, color, luster, shape and the type of flaws present in the pearls.

Opinions differ as to the causes of instability in the pearl market. As pearls are a luxury commodity, demand is linked to the economies of the richer nations. There is no evidence of overproduction, on its own, causing a collapse in prices. The dramatic fall in the Japanese pearl market in the 1960s was apparently compounded by overproduction, but originated in the deteriorating quality of the pearls due mainly to worsening water quality (refer to pollution section, p. 12). The overall quality of the pearls coming from Japan is still lower than that attained before the 1960s.

Since 1983, pearls have been the top export earner for French Polynesia, US\$41.1 million worth exported to Japan alone in 1989 (McElroy 1990). Pearl production is expected to be the top export earner of the Cook Islands in 1991. Japan produced 70 t of marine pearls in 1988 worth an estimated ¥61,163 million (US\$476 million) and

imported a further ¥13,973 million and ¥21,149 million from the major marine pearl producing countries in 1988 and 1989, respectively.

Marketing studies are urgently needed. *P. maxima* prices are currently high. Some producers are fearful of an oversupply, while others believe that the market is still expanding. The price per kg of black pearls has been consistently rising

with increasing production, suggesting an expanding market. Some producers believe that an annual output of at least 1,000 kg of jewelry grade black pearls is necessary to make the black pearl fully accepted by the marketplace (McElroy 1990). As current production is believed to be approximately 600 kg·year<sup>-1</sup>, prospects for market expansion appear good.

## CONCLUSIONS

Pearl oyster cultivation and pearl culture are developing rapidly throughout the Pacific Islands region. There is still further potential for geographic expansion of pearl culture and for improved management and marketing of the current industry.

To sustain these developments, several specific research questions need to be addressed. Priority areas include:

1. hatchery culture techniques for *P. maxima* and *P. margaritifera* need to be refined and made widely available. Commercial pearl oyster hatcheries will permit farming in areas where natural spatfall are insufficient and will allow for genetic improvements of farm stocks;
2. where stocks are currently marginal, or heavily exploited, population assessment surveys need to be conducted, with the dual aims of assessing pearl culture potential in the area and providing a baseline for monitoring the impacts of future exploitation;
3. spat collection techniques for *P. maxima* need to be developed; and
4. comparative studies of pearl oyster parasites and pathogens need to be undertaken in the wild and under culture conditions. Pearl oyster disease management strategies need to be developed and applied as farms become established.

Improvements in pearl production processes could also be fostered through sharing of technology and collaborative research programs between technicians and established and developing farm

areas. Research priorities for materials and methods used in pearl seeding operations include:

1. identification of suitable alternative materials and sources of nuclei, particularly for nuclei above 13-mm diameter;
2. evaluation of preoperative procedures (conditioning), the use of relaxants and prophylactic drugs during seeding, and postoperative procedures (handling and environmental conditions); and
3. development of methods for the tissue culture of mantle epithelium and its implantation during seeding operations.

Development priorities in the Pacific Islands should focus on:

1. refinement of appropriate farming systems and extension programs to coastal villages where expansion of farming is possible;
2. increasing the availability of seeding technicians through collaborative training programs of Pacific Island nations; and
3. definition of optimum marketing strategies for Pacific Island pearls. The sources of volatility in the market should be identified and cooperative approaches should be encouraged between pearl producing island countries.

There is also a need for improved communication between pearl oyster researchers and pearl farmers throughout the Pacific. Language differences are a further hindrance. Translation of scientific literature into Japanese, French, and English would make the existing body of work more accessible and could prevent duplication of research efforts.

## ACKNOWLEDGEMENTS

The following people were most generous in their time and knowledge while MG was on study tour in Australia and Japan. Mr. R. Scoones and Mr. M. Buckley of Broome Pearls; Dr. R. Rose of Pearl Oyster Propagators; Dr. L. Joll, Western

Australia Fisheries Department; Mr. N. Paspaley of Paspaley Pearls; Mr. A. Bell of South Sea Pearling; Drs. K. Wada, S. Funakoshi, T. Suzuki, A. Komaru and M. Awaji of the National Research Institute of Aquaculture, Mie, Japan; Dr. Seko;



Dr. M. Muramatsu and Mr. J. Fukushima of Tasaki Shinju and Mr. J. Branellec of Jewelmer International. Their assistance is gratefully acknowledged.

Drs. R.J. MacIntyre and P. Dixon, Centre for Marine Studies, University of New South Wales, provided guidance and critical review of earlier drafts of this work by NS. Dr. J.L. Munro of ICLARM provided much patient editorial advice for more recent drafts while Drs. R. Rose and K.T. Wada reviewed the final manuscript.

This review complements the work - Gervis, M. 1991. A bibliography of the pearl oysters

(Bivalvia: Pteriidae). ICLARM Bibliogr. 11, 99 p., which was also funded by the Overseas Development Administration of the United Kingdom.

M.H. Gervis was funded during this review by the Overseas Development Administration of the United Kingdom, while on secondment to ICLARM. The funding also provided for study tours to the Japanese and Australian pearl culture centers. Some sections of this work were previously submitted by N.A. Sims as part of his MSc from the University of New South Wales, Australia. The work was entitled "The blacklip pearl oyster, *P. margaritifera*. A literature review".

## REFERENCES

- Achari, G.P.K. 1980. New designs of spat collectors, breeding hapas, cages and improved technology of pearl farming. Symposium on Coastal Aquaculture, 12-18 January 1980. Part 2. Molluscan culture. Symp. Ser. Mar. Biol. Assoc. India 6: 704. (Abstract).
- Alagarwami, K. 1970. Pearl culture in Japan and its lessons for India, p. 975-998. *In* Proceedings of the Symposium on Mollusca. Part III. Marine Biological Association, India.
- Alagarwami, K. 1975. Preliminary study on the growth of cultured pearls. *Indian J. Fish.* 22(1-2): 300-303.
- Alagarwami, K. 1987. Technology of cultured pearl production, p. 98-106. *In* K. Alagarwami (ed.) Pearl culture. Bull. Cent. Mar. Fish. Res. Inst. No. 39. Central Marine Fisheries Research Institute, Cochin, India.
- Alagarwami, K. and A. Chellam. 1976. On fouling and boring organisms and mortality of pearl oysters in the farm at Veppalodai, Gulf of Mannar. *Indian J. Fish.* 23(1-2): 10-22.
- Alagarwami, K. and A. Chellam. 1977. Change of form and dimensional relationship in the pearl oyster *Pinctada fucata* from Gulf of Mannar. *Indian J. Fish.* 24(1-2): 1-14.
- Alagarwami, K. and A.C.C. Victor. 1976. Salinity tolerance and rate of filtration of the pearl oyster, *P. fucata*. *J. Mar. Biol. Assoc. India* 18(1): 149-158.
- Alagarwami, K., K. Dharmaraj, T.S. Velayudhan, A. Chellam and A.C.C. Victor. 1983a. On the controlled spawning of the Indian pearl oyster *Pinctada fucata* (Gould). Symposium on Coastal Aquaculture, 12-18 January 1980. Part 2. Molluscan culture. Symp. Ser. Mar. Biol. Assoc. India 6: 590-597.
- Alagarwami, K., Dharmaraj, T.S. Velayudhan, A. Chellam and A.C.C. Victor. 1983b. Embryonic and early larval development of pearl oyster *Pinctada fucata* (Gould). Symposium on Coastal Aquaculture, 12-18 January 1980. Part 2. Molluscan culture. Symp. Ser. Mar. Biol. Assoc. India 6: 598-603.
- Alagarwami, K., Dharmaraj, T.S. Velayudhan, A. Chellam, A.C.C. Victor and A.D. Gandhi. 1983c. Larval rearing and production of spat of pearl oyster *Pinctada fucata* (Gould). *Aquaculture* 34: 287-301.
- Alagarwami, K., Dharmaraj, T.S. Velayudhan and A. Chellam. 1987. Hatchery technology for pearl oyster production, p. 62-71. *In* K. Alagarwami (ed.) Pearl culture. Bull. Cent. Mar. Fish. Res. Inst. No. 36. Central Marine Fisheries Research Institute, Cochin, India.
- Alagarwami, K., Dharmaraj, A. Chellam and T.S. Velayudhan. 1989. Larval and juvenile rearing of black-lip pearl oyster, *Pinctada margaritifera* (Linnaeus). *Aquaculture* 76(1-2): 43-56.
- Allen, A.W. 1906. Some notes on the life history of *Margaritifera panasesae*. *J. Linn. Soc. (Zool.)* 29: 410-413.
- Anon. 1956. Closing Minihiki lagoon is unnecessary. *The Pacific Islands Monthly*. March 1956: 47.
- Anon. 1973. Mother of pearl, *Pinctada margaritifera*. *Australian Fisheries*. December 1973, Plate No. 22.
- Anon. 1987. Mother-of-pearl, *Pinctada margaritifera*. *Aust. Fish.* December 1973: Plate No. 22.
- Anon. 1985. Department develops oyster culture techniques. *FINS* 18(2): 3-6.
- Aoki, S. 1956. Formation of the pearl-sac in the pearl-oyster (*Pinctada martensii*), with reference to the autumn and early winter pearl-culture. *Bull. Natl. Pearl Res. Lab.* 1: 41-46.
- Aoki, S. 1959a. Some experiments on the nuclear insertion in the pearl culture of the pearl oyster *Pinctada martensii* (Dunker). III. Formation of the pearl-sac and the pearl when the pieces from three different parts of the mantle were inserted. *Bull. Natl. Pearl Res. Lab.* 5: 503-515.
- Aoki, S. 1959b. Som experiments on the nuclear insertion in the pearl culture of the pearl oyster *Pinctada martensii* (Dunker). IV. On the quality and shape of the cultured pearl in relation to the site of the pearl formation. *Bull. Natl. Pearl Res. Lab.* 5: 516.
- Appukkuttan, K.K. 1987. Pearl oyster culture in Vizahinjham Bay, p. 54-61. *In* K. Alagarwami (ed.) Pearl culture. Bull. Cent. Mar. Fish. Res. Inst. No. 39. Central Marine Fisheries Research Institute, Cochin, India.
- AQUACOP. 1982. French Polynesia - Country report, p. 31-33. *In* F.B. Davy and M. Graham (eds.) Bivalve culture in Asia and the Pacific. Proceedings of a workshop held in Singapore, 16-19 February 1982. International Development Research Centre, Ottawa.
- Arakawa, K.Y. 1980. Prevention and removal of fouling on cultured oysters. A handbook for growers. *Marine Sea Grant Tech. Rep.* 56, 38 p.
- Banner, A.H. 1952. Preliminary report on marine biology study of Onotoa Atoll, Gilbert Islands. *Atoll Res. Bull.* 13: 1-42.
- Baqueiro, E. and M. Castagna. 1988. Fishery and culture of selected bivalves in Mexico: past, present and future. *J. Shellfish Res.* 7(3): 433-443.
- Barash, A. and Z. Danin. 1986. Further additions to the knowledge of Indo-Pacific Mollusca in the Mediterranean Sea (Lessepsian migrants). *Spixian* 9(2): 117-141.
- Beaubrun, P.C. 1972. [Attempts at introducing two new breeding molluscs to Morocco]. *Essais d'introduction de deux mollusques d'élevage nouveaux pour le Maroc*. *Bull. Inst. Pêches Marit. Maroc* 20: 111-119.
- Berry, G.N. and L.R.G. Cannon. 1981. The life history of *Sulcascaris sulcata* (Nematoda: Ascaridoidea) a parasite of marine molluscs and turtles. *Int. J. Parasitol.* 11(1): 43-54.
- Bevelander, G. and H. Nakahara. 1969. An electron microscope study of the formation of the nacreous layer in the shell of certain bivalve molluscs. *Calcified Tissue Res.* 3: 84-92.
- Blanc, F. 1983. Estimation du polymorphisme enzymatique dans trois populations naturelles de nacre (*Pinctada margaritifera*) en Polynésie Française. *C.R. Acad. Sci. Paris* 297: 199-202.
- Blanc, F., P. Durand and M. Shinh-Milhaud. 1985. Genetic variability in populations of black pearl oyster *Pinctada*

- margaritifera* (mollusc bivalve) from Polynesia. Proc. 5th Int. Coral Reef Congress Tahiti 4: 113-118.
- Brown, M., S.W. Jeffrey and C.D. Garland. 1989. Nutritional aspects of micro-algae used in mariculture: a literature review. CSIRO Mar. Lab. Rep. 206: 1-44.
- Bullivant, J.S. 1962. Direct observation of spawning in the blacklip pearl shell oyster (*Pinctada margaritifera*) and the thorny oyster (*Spondylus* sp.). Nature 193(4816): 700-701.
- Cabral, O., K. Mizuno and A. Tauru. 1985. Preliminary data on the spat collection of mother of pearl (*Pinctada margaritifera*, bivalve, mollusc) in French Polynesia. Proc. 5th Int. Coral Reef Congress Tahiti 5: 177-182.
- Cahn, A. 1949. Pearl culture in Japan. United States Department of the Interior. Fish and Wildlife Service. Fishery leaflet 357: 1-91.
- Cernohorsky, W.O. 1978. Tropical Pacific marine shells. Pacific Publications (Aust.) Pty. Ltd., Sydney.
- Chellam, A. 1978. Growth of pearl oyster *Pinctada fucata* in the pearl culture farm at Veppalodai. Indian J. Fish. 25(1-2): 77-83.
- Chellam, A. 1983. Study on the stomach contents of pearl oyster *Pinctada fucata* (Gould) with reference to the inclusion of bivalve eggs and larvae. Symposium on Coastal Aquaculture, 12-18 January 1980. Part 2. Molluscan culture. Symp. Ser. Mar. Biol. Assoc. India 6: 604-607.
- Chellam, A. 1987. Biology of pearl oyster, p. 13-29. In K. Alagarwami (ed.) Pearl culture. Bull. Cent. Mar. Fish. Res. Inst. No. 39. Central Marine Fisheries Research Institute, Cochin, India.
- Chellam, A., T.S. Velayudhan, S. Dharmaraj, A.C.C. Victor and A.D. Gandhi. 1983. A note on the predation of the pearl oyster *Pinctada fucata* by some gastropods. Indian J. Fish. 30(2): 337-339.
- Chellam, A., S. Dharmaraj and A.C.C. Victor. 1987a. Experimental sea-ranching of pearl oyster in the Gulf of Mannar, p. 90-91. In K. Alagarwami (ed.) Pearl culture. Bull. Cent. Mar. Fish. Res. Inst. No. 39. Central Marine Fisheries Research Institute, Cochin, India.
- Chellam, A., T.S. Velayudhan, and A.C.C. Victor. 1987b. Pearl oyster farming, p. 72-77. In K. Alagarwami (ed.) Pearl culture. Bull. Cent. Mar. Fish. Res. Inst. No. 39. Central Marine Fisheries Research Institute, Cochin, India.
- Cheng, T.C. 1967. Marine molluscs as hosts for symbiosis, with a review of known parasites of commercially important species. Adv. Mar. Biol. 5: 1-424.
- Cheong, L. and H.B. Lee. 1984. Mussel farming. SAFIS Extension Manual No. 5, 51 p. Southeast Asian Fisheries Development Center, Bangkok, Thailand.
- Coeroli, M. 1983. *Pinctada margaritifera*, p. 1-20. In Milieu lagunaire. Etat des connaissances. Pêche Document No. 7. E.V.A.A.M. Service de la Mer, Polynésie Française.
- Coeroli, M., D. De Gaillande, J.P. Landret and D. Coatanea. 1984. Recent innovations in cultivation of molluscs in French Polynesia. Aquaculture 39(1-4): 45-67.
- Crossland, C. 1911. The marginal processes of lamellibranch shells. Proc. Zool. Soc. Lond. 1911: 1057-1061.
- Crossland, C. 1957. The cultivation of the mother of pearl oyster in the Red Sea. Aust. J. Mar. Freshwat. Res. 8: 111-130.
- Currey, J.D. 1977. Mechanical properties of mother of pearl in tension. Proc. R. Soc. London 196B: 443-463.
- Currey, J.D. 1980. Mechanical properties of mollusc shell. Symp. Soc. Exp. Biol. 34: 75-97.
- Currey, J.D. and K. Brear. 1984. Fatigue fracture of mother-of-pearl and its significance for predatory techniques. J. Zool. 203(4): 541-548.
- Desai, K., G. Hirani and D. Nimavat. 1979. Studies on the pearl oyster, *Pinctada fucata* (Gould): seasonal biochemical changes. Indian J. Mar. Sci. 8(1): 49-50.
- Devanesan, D.W. and K. Chidambaram. 1966. Results obtained at the pearl-oyster farm, Krusadai Island, Gulf of Mannar, and their application to problems relating to pearl fisheries in the Gulf of Mannar. Part I. Contribution from the Marine Fisheries Biological Station, Krusadai Island, Gulf of Mannar 4: 1-89.
- Dharmaraj, S. and A. Chellam. 1983. Settlement and growth of barnacle and associated fouling organisms in pearl culture farm in the Gulf of Mannar. Symposium on Coastal Aquaculture, 12-18 January 1980. Part 2. Molluscan culture. Symp. Ser. Mar. Biol. Assoc. India 6: 608-613.
- Dharmaraj, S., A. Chellam and T.S. Velayudhan. 1987a. Biofouling, boring and predation of pearl oyster, p. 92-97. In K. Alagarwami (ed.) Pearl culture. Bull. Cent. Mar. Fish. Res. Inst. No. 39. Central Marine Fisheries Research Institute, Cochin, India.
- Dharmaraj, S., K. Kandasami and K. Alagarwami. 1987b. Some aspects of physiology of Indian pearl oysters, p. 21-28. In K. Alagarwami (ed.) Pearl culture. Bull. Cent. Mar. Fish. Res. Inst. No. 39. Central Marine Fisheries Research Institute, Cochin, India.
- Domard, J. 1959. Diving for pearl shell in French Polynesia. S.P.C. Q. Bull. October 1959: 32-33.
- Domard, J. 1962. Les bancs nacrés de la Polynésie Française. Leur exploitation, leur conservation, leur reconstitution. Comm. Pac. Sud. Conf. Techn. Pêches, 5-13 février 1962, Nouméa, Nouvelle Calédonie.
- Dybdahl, R. and D.A. Pass. 1985. An investigation of the mortality of the pearl oyster, *Pinctada maxima*, in Western Australia. Fisheries Department of Western Australia Report No. 71, 78 p.
- Farn, A.C. 1986. Pearls: natural, cultured and imitation. Butterworths Gem Books, London.
- Galtsoff, P.S. 1931. The weight-length relationship of the shells of the Hawaiian pearl oyster, *Pinctada* sp. Am. Nat. 65: 423-433.
- Galtsoff, P.S. 1933. Pearl and Hermes reef, Hawaii: hydrographical and biological observations. Bull. Bishop Mus. Honolulu 107: 3-49.
- George, C.D. 1967. The cultured pearl, its history and development to the present day. Lapidary J. Am. July-August-September: 1-6.
- George, C.D. 1969. Techniques of pearl cultivation. South Pac. Bull. 19(4): 13-19.
- George, C.D. 1978. The pearl. A report to the Government of Papua New Guinea, the Food and Agriculture Organization of the United Nations, and the Asian Development Bank. Samarai, Milne Bay Province, Papua New Guinea. 169 p.
- Gideiri, Y.B.A. 1983. Pearl oyster culture in Sudanese Red Sea. Symposium on Coastal Aquaculture, 12-18 January 1980. Part 2. Molluscan culture. Symp. Ser. Mar. Biol. Assoc. India 6: 584-586.
- Goggin, C.L. and R.J.G. Lester. 1987. Occurrence of *Perkinsus* species (Protozoa, Apicomplexa) in bivalves from the Great Barrier Reef. Dis. Aquat. Org. 3: 113-117.
- Gokhale, S.V., C.R. Easwaran and R. Narsihmhan. 1954. Growth-rate of the pearl oyster (*Pinctada fucata*) in the Gulf of Kutch with a note on the pearl fishery of 1953. J. Bombay Nat. Hist. Soc. 52(1): 124-136.
- Gug, M. 1957. Mother-of-pearl industry in French Oceania. S.P.C. Quarterly Bull. July 1957: 19-21.
- Hancock, D.A. 1973. Kuri Bay pearls some of the finest in the world. Aust. Fish. 32(4): 11-12.

- Hatano, H. 1971. Carbonate crystals and sclero proteins of pearl oyster shells and the mechanism of shell formation. *J. Geol. Soc. Jap.* 77(9): 597-605.
- Hatano, H., Y. Matsui, Y. Swada, S. Tanaka and Y. Uchida. 1955. Biochemical studies on the formation of pearl and the shell of pearl oyster and pearl mussel by using radio-active calcium. II. *Rep. Nippon. Inst. Sci. Res. Pearls* 44.
- Hauti, A., G.A. Tehoiri, M. Tchoung, G. Matitai, M. Gervais et T. Mercier. 1987. L'aquaculture nacrrière et perlière à Takapoto en 1986. *Ministère de la Mer, Service de la Mer et de l'Aquaculture*. 65 p.
- Hauti, A. et coll. 1988. L'aquaculture nacrrière et perlière à Ahe et à Manihi en 1987. *Ministère de la Mer, Service de la Mer et de l'Aquaculture*. 64 p.
- Hayashi, M. and K. Seko. 1986. Practical technique of artificial propagation of Japanese pearl oyster *Pinctada fucata*. *Bull. Fish. Res. Inst.* 1: 39-76.
- Hedley, C. 1924. Australian pearl fisheries. *Aust. Mus. Mag.* 2: 5-11.
- Herdman, W.A. 1903. Report to the Government of Ceylon on the pearl oyster fisheries of the Gulf of Manaar. Part I. *The Royal Society of London*. 146 p.
- Herdman, W.A. 1904. Report to the Government of Ceylon on the pearl oyster fisheries of the Gulf of Manaar. Part II. *The Royal Society London*. 106 p.
- Hollyer, J. 1984. Pearls - jewels of the sea. *Infofish Marketing Digest* 5: 32-34.
- Hornell, J. 1914a. An explanation of the irregularly cyclic character of the pearl fisheries. *Madras Fish. Bull.* 8, 22 p.
- Hornell, J.H. 1914b. A preliminary note on the preponderant factor governing the cyclic character of the pearl fisheries of Ceylon and south India, p. 644-647. *In IX Congress International de Zoologie*.
- Hornell, J. 1915. The recent pearl fishery in Palk Bay, with biological notes upon pearl oysters. *J & Proc. Asiatic Soc. Bengal (New Series)* XI(5&6):153-164.
- Hornell, J. 1922. The Indian pearl fisheries of the Gulf of Manaar and Palk Bay. *Bull. Madras Fish. Dept. Madras* 16: 1-188.
- Hynd, J.S. 1955. A revision of Australian pearl shells, genus *Pinctada*. *Aust. J. Mar. Freshwat. Res.* 6(1): 98-137.
- Hynd, J.S. 1960a. Report to the South Pacific Commission on an investigation of the blacklip mother-of-pearl oyster, *Pinctada margaritifera* (Linnaeus) in Manihiki, Cook Island. *CSIRO Marine Biological Laboratory, Cronulla, Sydney*. 70 p.
- Hynd, J.S. 1960b. An analysis of variation in Australian specimens of *Pinctada albina* (Lamarck) (Lamellibranchia). *Aust. J. Mar. Freshwat. Res.* 11(3): 326-364.
- Ikuta, K. 1986a. Correlations between ratios of metal concentrations in byssuses to those in soft bodies of bivalves. *Bull. Fac. Agric. Miyazaki Univ.* 33(2): 265-274.
- Ikuta, K. 1986b. Betal concentrations in byssuses and soft bodies of bivalves. *Bull. Fac. Agric. Miyazaki Univ.* 33(2): 255-264.
- Ikuta, K. 1987. Relations between biomass-water volume ratios and cadmium accumulation amounts in some marine mollusks. *Bull. Fac. Agric. Miyazaki Univ.* 34(1): 131-138.
- Intes, A. 1982a. Programme nacre: étude des stocks naturels. *Rapport de mission: Mission 82-02, Atoll de Manihi. ORSTOM et Service de la Pêche de Polynésie Française, Tahiti*.
- Intes, A. 1982b. Le stock naturel de nacre (*Pinctada margaritifera* L.) dans l'archipel des Gambiers. *Arch. Océanogr. Cent. Papeete ORSTOM* 82(2): 1-17.
- Intes, A. 1988. Méthodes d'évaluation des stocks d'huîtres nacrrières et perlières en Polynésie Française. *SPC Inshore Fisheries Research Workshop. Background Paper no. 66*, 10 p. *South Pacific Commission, Nouméa, Nouvelle Calédonie*.
- Intes, A. and M. Coeroli. 1985a. Evolution and condition of natural stocks of pearl oysters (*Pinctada margaritifera* Linne) in French Polynesia, p. 545-550. *In B. Delesalle, R. Galzin, B. Salvat, C. La Croix, A.E. Wolf, N. Theibaut and G. Poli (eds.) Vth International Coral Reef Congress. Vol. 5. International Association for Biological Oceanography, Tahiti, French Polynesia*.
- Intes, A. et M. Coeroli. 1985b. L'huître perlière de Polynésie Française: bibliographie. *ORSTOM, Papeete, Tahiti*. 10 p.
- Intes, A., P. Laboute and M. Coeroli. 1986. Le stock naturel de nacre (*Pinctada margaritifera* L.) dans l'atoll de Scilly (Archipel de la Société, Polynésie Française). *Notes Doc. Océanogr. Cent. Tahiti ORSTOM* 31: 1-38.
- Iredale, T. 1939. *Mollusca: Part I. Sci. Rep. Gr. Barrier Reef Exped.* 5: 209-425.
- Jacob, P.G., M.A. Zarba and V. Anderlini. 1980. Biochemical and related features of benthic mud of Kuwaiti waters. *Indian J. Mar. Sci.* 9(2): 100-105.
- Jameson, H.L. 1901. On the identity and distribution of the mother of pearl oysters with a revision of the subgenus *Margaritifera*. *Proc. Zool. Soc. London* 1: 372-394.
- Johns, T.G. and R.W. Hickman. 1985. A manual for mussel farming in semi-exposed coastal waters; with a report on the mussel research at Te Kaha, eastern Bay of Plenty, New Zealand, 1977-82. *Fisheries Research Division Occasional Publication No. 50*, 28 p.
- Jorgensen, C.B. 1970. *The biology of suspension feeding*. Pergamon Press, Oxford.
- Kafuku, T. and H. Ikenoue. 1983. Pearl oyster (*Pinctada fucata*), p. 161-171. *In Modern methods of aquaculture in Japan. Developments in Aquaculture and Fisheries Science. Elsevier Scientific Publishing Co., Amsterdam*.
- Kakazu, K., M. Sesoko and H. Nakano. 1971. Studies on mass production of juveniles of blacklip oysters *P. margaritifera* (L.) III: on food selection of the larvae and optimum water temperature for rearing in tanks. *Biol. Mag. Okinawa* 8: 30-36.
- Kawakami, I.K. 1952a. Studies on pearl sac formation. 1. On the regeneration and transplantation of the mantle piece in the pearl oyster. *Mem. Fac. Sci. Kyushu Univ. (Ser. E)* 1(2): 83-89.
- Kawakami, I.K. 1952b. Mantle regeneration in pearl oyster (*Pinctada martensii*). *J. Fuji Pearl Inst.* 2(2): 1-4.
- Kawamoto, N.Y. and E. Motoki. 1954. Influence of diluted sea water on the pearl oyster *Pinctada martensii* (Dunker). *Rep. Fac. Fish. Pref. Univ. Mie* 1(3): 346-354.
- Kikuchi, Y. and N. Tamiya. 1987. Chemical taxonomy of the hinge ligament proteins of bivalves according to their amino acid compositions. *Biochem. J.* 242(2): 505-510.
- Kinzelbach, R. 1984. Lessepsian migration: new records of mussels, *Bivalvia, Anisomyaria*. *Arch. Molluskenkd.* 115(4-6): 273-278.
- Klumpp, D.W. and C. Burdon-Jones. 1982. Investigations of the potential of bivalve molluscs as indicators of heavy metal levels in tropical marine waters. *Aust. J. Mar. Freshwat. Res.* 33 (2): 285-300.
- Kobayashi, S. and M. Tobata. 1949a. Studies on culture pearl, II. Activity of pearl oyster in winter (1). *Bull. Jap. Soc. Sci. Fish. (Nippon Suisan Gakkaishi)* 14(4): 196-199.
- Kobayashi, S. and M. Tobata. 1949b. Studies on culture of pearl. III. Activity of pearl oyster in winter (2). *Bull. Jap. Soc. Sci. Fish. (Nippon Suisan Gakkaishi)* 14: 200-202.

- Komaru, A. and K.T. Wada. 1985. Karyotype of the Japanese pearl oyster, *Pinctada fucata martensii*, observed in the trochophore larvae. Bull. Natl. Res. Inst. Aquacult. (Japan)/Yoshokukenhō 7: 105-107.
- Korringa, P. 1952. Recent advances in oyster biology. Q. Rev. Biol. 27: 266-308 and 339-365.
- Kunz, G.F. and C.H. Stevenson. 1908. The book of the pearl: the history, art, science and industry of the queen of gems. The Century Company, New York. 548 p.
- Kuwatani, Y. 1965a. A study on feeding mechanism of Japanese pearl oyster, *Pinctada martensii* (Dunker), with special reference to passage of charcoal particles in the digestive system. Bull. Jap. Soc. Sci. Fish. (Nippon Suisan Gakkaishi) 31: 789-798.
- Kuwatani, Y. 1965b. On the anatomy and function of the stomach of Japanese pearl oyster, *Pinctada martensii* (Dunker). Bull. Jap. Soc. Sci. Fish. (Nippon Suisan Gakkaishi) 31: 174-186.
- Kuwatani, Y. 1965c. Studies on the breeding of the Japanese pearl oyster *Pinctada martensii* (Dunker). I. Change in the maturation of the eggs obtained from the excised gonads during the spawning season. Bull. Natl. Pearl Res. Lab. 10: 1228-1243.
- Ladd, H.S. 1960. Origin of the Pacific island molluscan fauna. Amer. J. Sci. V258A: 137-150.
- Larkum, A.W.D. 1983. The primary productivity of plant communities on coral reefs, p. 221-230. In D.J. Barnes (ed.) Perspectives on coral reefs. Australian Institute of Marine Science, Brian Clouston, Manuka, A.C.T. 277 p.
- Li, G., G. Jin, W. Jiang and Y. Wei. 1985. Biochemical genetic variation in the pearl oysters *Pinctada fucata* and *Pinctada chemnitzii*. Acta. Genet. Sin. 12(3): 204-212.
- Lintilhac, J.P. 1985. Les perles noires de Tahiti. Pacific Editions, Tahiti. 88 p.
- Lock, J.M. 1982. Country reports: Papua New Guinea, p. 53-54. In F.B. Davy and M. Graham (eds.) Bivalve culture in Asia and the Pacific. International Development Research Centre, Ottawa, Ontario.
- Lowe, J. 1986. Report on visit to Ahe (French Polynesia) in December 1986. 16 p. (MS)
- Machii, A. 1961. Studies on the technique so-called 'Atosuke' (one of the methods of nuclear insertion in pearl culture). III. On the pearl-sac formation. Bull. Natl. Pearl Res. Lab. 6: 642-646.
- Mansour, K. 1946a. Extracellular proteolytic and lipolytic enzymes of some lamellibranchs. Nature 158: 378-379.
- Mansour, K. 1946b. Food and the digestive processes of the Lamellibranchs. Nature 157: 482-482.
- Mansour, K. and M.N. Gabal. 1980. Food and feeding of the pearl oysters and some other lamellibranchs of the Red Sea. Proc. Egypt. Acad. Sci. 33: 209-216.
- Matsui, Y. 1958. Aspects of the environment of pearl-culture grounds and the problems of hybridization in the genus *Pinctada*, p. 519-531. In A.A. Buzzati-Traverso (ed.) Perspectives in marine biology. University of California Press, Berkeley and Los Angeles.
- McConchie, D.M., A.W. Mann, M.J. Lintern, D. Longman, V. Talbot, A.J. Gabelish and M.J. Gabelish. 1988. Heavy metals in marine biota sediments and waters from the Shark Bay area, Western Australia. J. Coastal Res. 4(1): 37-58.
- McElroy, S. 1990. The Japanese pearl market. Infofish Intl. 90(6): 17-23.
- McShane, P.E., M.G. Smith and K.H.H. Beinssen. 1988. Growth and morphometry in abalone *Haliotis rubra* (Leach) from Victoria. Aust. J. Mar. Freshwat. Res. 39: 161-166.
- Millous, O. 1977. Etude des possibilites de production de naissain de nacre en laboratoire. CNEXO, Centre Oceanologique du Pacifique, Taravao, Tahiti. 30 p.
- Millous, O. 1980. Essai de production contrôlée du naissain d'huîtres perlières (*P. margaritifera*) en laboratoire. Rapp. CNEXO/Cop/Ag. Tahiti. 80 p.
- Minaur, J. 1969. Experiments on the artificial rearing of the larvae of *Pinctada maxima* (Jameson) (Lamellibranchia). Aust. J. Mar. Freshwat. Res. 20: 175-187.
- Mizumoto, S. 1964. Studies on disease of the shells of the pearl oyster (*Pinctada martensii*). On the species of parasitic polychaetes in shells, the conditions of the damages and the extirpation technique. Bull. Natl. Pearl Res. Lab. 9: 1143-1155.
- Mizumoto, S. 1976. Pearl farming in Japan. A review, p. 381-385. In T.V.R. Pillay (ed.) FAO Technical Conference on Aquaculture, Kyoto, Japan, 26 May 1976. FAO-FIR: AQ/Conf.76.R.13.
- Mohammad, M.B.M. 1972. Infestation of the pearl oyster *Pinctada margaritifera* (Linné) by a new species of *Polydora* in Kuwait, Arabian Gulf. Hydrobiologia 39(4): 463-477.
- Mohammad, M.B.M. 1976. Relationship between biofouling and growth of the pearl oyster *Pinctada fucata* (Gould) in Kuwait, Arabian Gulf. Hydrobiologia 51(2): 129-138.
- Nakahara, H. and G. Bevelander. 1971. The formation and growth of the prismatic layer of *Pinctada radiata*. Calcified Tissue Res. 7(1): 31-45.
- Nalluchinnappan, I., D.S. Dev, M. Irulandy and Y. Jeyabaskaran. 1982. Growth of pearl oyster *Pinctada fucata* in cage culture at Kundugal Channel Gulf of Mannar, India. Indian J. Mar. Sci. 11(2): 193-194.
- Narayanan, K.R. and M.S. Michael. 1968. On the relation between age and linear measurements of the pearl oyster, *Pinctada vulgaris* (Schumacher), of the Gulf of Kutch. J. Bombay Nat. Hist. Soc. 65(2): 441-452.
- Nasr, D.H. 1982. Observations on the mortality of the pearl oyster, *Pinctada margaritifera* in Dongonab Bay, Red Sea. Aquaculture 28(3-4): 271-281.
- Nasr, D.H. 1984. Feeding and growth of the pearl oyster *Pinctada margaritifera* in Dongonab Bay, Sudan, Red Sea. Hydrobiologia 110: 241-246.
- Nayar, K.N., S. Mahadevan, K. Ramadoss, N. Sundaram and C.T. Rajan. 1978. Experimental study of the settlement and collection of pearl oyster spat from Tuticorin area. Indian J. Fish. 25(1-2): 246-252.
- Nayar, N.K. and S. Mahadevan. 1987. Ecology of pearl oyster beds. Bull. Cent. Mar. Fish. Res. Inst. 39: 29-36.
- Nicholls, A.G. 1931. On the breeding and growth rate of the black-lip pearl oyster (*Pinctada margaritifera*). Rept. Gt. Barrier Reef Comm. 3: 26-31.
- Numaguchi, K. 1985. Studies on phaeophytin contained in the digestive diverticula of pearl oyster, *Pinctada fucata martensii*, as index of feeding of phytoplankton. Bull. Natl. Res. Inst. Aquacult. (Japan)/Yoshokukenhō 7: 91-96.
- Numaguchi, K. and Y. Tanaka. 1986a. Effects of salinity on mortality and growth of the spat of the pearl oyster *Pinctada fucata martensii*. Bull. Natl. Res. Inst. Aquacult. (Japan)/Yoshokukenhō 9: 41-44.
- Numaguchi, K. and Y. Tanaka. 1986b. Effects of temperature on mortality and growth of the spat of the pearl oyster, *Pinctada fucata martensii*. Bull. Natl. Inst. Aquaculture 9: 35-39.
- Orton, J.H. 1928. On rhythmic periods in shell growth in *Ostrea edulis* with a note on fattening. J. Mar. Biol. Assoc. U.K. 15: 365-427.

- Ota, S. 1957. Notes on the identification of free swimming larvae of pearl oyster (*Pinctada martensii*) Bull. Natl. Pearl Res. Lab. 2: 128-132.
- Ota, S. 1959. Studies on feeding habits of *Pinctada martensii*. V. Number and size of swimming bivalve larvae fed by pearl oyster in summer. Bull. Natl. Pearl Res. Lab. 5: 443-449.
- Pandya, J. 1975. Age and growth of the pearl oyster *Pinctada vulgaris* (Schumacher), of the Gulf of Kutch. J. Indian Fish. Assoc. 2(1-2): 47-54.
- Pandya, J.A. 1976. Influence of temperature on growth ring formation in the pearl oyster, *Pinctada fucata* (Gould), of the Gulf of Kutch. Indian J. Mar. Sci. 5(2): 249-251.
- Pass, D.A., R. Dybdahl and M.M. Mannion. 1987. Investigations into the causes of mortality of the pearl oyster, *Pinctada maxima* (Jameson), in Western Australia. Aquaculture 65(2): 149-169.
- Pass, D.A. and F.P. Perkins. 1985. Protistan parasites or residual bodies in *Pinctada maxima*. J. Invertebr. Pathol. 46(2): 200-201.
- Passfield, R. 1989. Basic requirements to set up a small pearl farm. South Pacific Commission Library, Noumea, New Caledonia. 2 p.
- Pauly, D. and J.L. Munro. 1984. Once more on the comparison of growth in fish and invertebrates. Fishbyte 2(1): 21.
- Pearse, J.S. 1974. Reproductive patterns of tropical reef animals: three species of sea urchins. Proc. 2nd Int. Coral Reef Symp. 1: 235-240.
- Penn, J.W. and R. Dybdahl. 1988. A research vessel survey of pearl oyster and prawn resources northwest of Broome, Western Australia. Fisheries Report No. 81, 24 p. Fisheries Department, Perth, Australia.
- Philipson, P.W. 1989. The marketing and processing of pearl shell in South Korea, Taiwan and Japan, p. 224-238. In P.W. Philipson (ed.) The marketing of marine products from the South Pacific. Institute of Pacific Studies of the University of the South Pacific, Suva, Fiji.
- Poirot, J.P. 1980. Éléments de gemmologie. Paris, Institut National de Gemmologie.
- Potter, M. 1984. Mollusc culture in Queensland, p. 47-55. In B.R. Pollock and R.H. Quinn (eds.) The potential of aquaculture in Queensland. Conf. Workshop Ser. Department of Primary Industries, Fisheries Research Branch, Brisbane, Queensland.
- Preston, G. 1990. Spat collector construction costs. SPS Pearl Oyster Info. Bull. 1: 7-9.
- Quayle, D.B. 1952. The rate of growth of *Venerupis pullastra* (Montagu) at Millport, Scotland. Proc. R. Soc. Edinb. B. 64: 348-406.
- Rahma, I.H. and G.F. Newkirk. 1987. Economics of tray culture of the mother-of-pearl shell *Pinctada margaritifera* in the Red Sea, Sudan. J. World Aquacult. Soc. 2 (3): 156-161.
- Ranson, G. 1957. Observations sur l'époque de la reproduction de *Pinctada margaritifera* et de quelques autres organismes marins dans les Tuamotu. La cause du nanisme de *P. margaritifera* dans le lagon de Takapoto, p. 1077-1080. In Proceedings of the 8th Pacific Science Congress. Vol. III. National Research Council of the Philippines, Diliman.
- Ranson, G. 1962. Mission dans le Pacifique. Récifs coralliens. Huîtres perlières. Lechevalier éd., Paris. 99 p.
- Rao, K.V. 1967. Pearl oysters of the Indian region. Proc. Symp. Mollusca Mar. Biol. Assoc. India 3: 1017-1028.
- Rao, K.V. 1970. Pearl oysters of the Indian region. Proc. Symp. Mollusca Mar. Biol. Assoc. India (3): 1017-1028.
- Rao, K.V. and S.K. Rao. 1974. Pearl oysters, p. 84-105. In R.V. Nair and K.S. Rao (eds.) The commercial molluscs of India. Bull. Cent. Mar. Fish Res. Inst No. 25. Cochin, India.
- Raymont, J.E.G. 1963. Plankton and productivity in the oceans. International series of monographs on pure and applied biology. Zoology, Volume 18. Pergamon Press, New York. 660 p.
- Reed, W. 1962. Report to the government of Sudan on the Sudanese shell industry and Red Sea fisheries based on the work of W. Reed. FAO Rep. 1489: 1-47.
- Reed, W. 1966. Cultivation of the black-lipped pearl oyster *Pinctada margaritifera* (L.). J. Conc. London 26: 26-32.
- Reed, W. 1985. Brief report on prospects for pearl farm at Ahe-Perle du Pacifique Sud. 7 p. (MS)
- Richard, G. 1985. Richness of the great sessile bivalves in Takapoto Lagoon, p. 368-371. In B. Delesalle, R. Galzin, B. Salvat, C. La Croix, A.E. Wolf, N. Theibaut and G. Poli (eds.) Vth International Coral Reef Congress. Vol. 1. International Association for Biological Oceanography, Tahiti, French Polynesia.
- Roberts, R.B. and R.A. Rose. 1989. Evaluation of some shells for use as nuclei for round pearl culture. J. Shellfish Res. 8(2): 387-390.
- Rose, R.A. and S.B. Baker. 1989. Research and development of hatchery and nursery culture for the pearl oyster *Pinctada maxima*. FIRTA Project 87/82. Final Report September 1989. 26 p.
- Rose, R.A., R. Dybdahl and S. Harders. 1990. Reproductive cycle of the Western Australian silver lip pearl oyster, *Pinctada maxima* (Jameson) (Mollusca: Pteriidae). J. Shellfish Res. 9(2): 261-272.
- Rose, R.A., R. Dybdahl, S. Sanders and S. Baker. 1986. Studies on artificially propagating the gold or silver-lipped pearl oyster, *Pinctada maxima* (Jameson), p. 60-67. In R.E. Pyne (ed.) Darwin Aquaculture Workshop. Technical Report No. 3. Fisheries Division, Department of Primary Industry and Fisheries. Australian Gov. Publ. Serv., Canberra.
- Sagara, J. and Y. Takemura. 1960. Studies on the age determination of the silver-lip pearl oyster, *Pinctada maxima* (Jameson). Bull. Tokai Reg. Fish. Res. Lab. 27: 7-14.
- Salvat, B. et C. Rives. 1980. Coquillages de Polynésie. Les éditions du Pacifique, Papeete, Tahiti. 391 p.
- Saville-Kent, W. 1890. On the experimental cultivation of the mother-of-pearl shell *Meleagrina margaritifera* in Queensland. Rep. Aust. Ass. Adv. Sci. 2: 541-548.
- Saville-Kent, W. 1893. Pearl and pearl-shell fisheries, p. 204-224. In The Great Barrier Reef of Australia: its products and potentialities. W.H. Allen & Co., London.
- Saville-Kent, W. 1905. Torres Straits pearlshell fisheries, p. 1075-1078. In Queensland parliamentary papers: Session 2 of 1905. Vol 2. Report to both Houses of Parliament. Government Printer, Brisbane.
- Scheltema, R.S. 1971. Larval dispersal as a means of genetic exchange between geographically separated populations of shallow-water benthic marine gastropods. Biol. Bull. 140: 284-322.
- Service de la Pêche. 1970. Etude sur l'industrie nacrrière en Polynésie Française. Bull. Tech. No. 2. Service de la Pêche, Tahiti, Polynésie Française. 34 p.
- Setoguchi, I. 1964. Basic experiments concerning propagation of *Pinctada margaritifera* (L.) VI. Feed organisms for larval cultivation. p. 253-258. In Annual Report Kagoshima Prefectural Experimental Station, 1963.
- Setoguchi, I. 1966. Experiments on indoor nursery stock selection of *Pinctada margaritifera*, p. 277-281. In Annual Report Kagoshima Prefectural Experimental Station, 1965.
- Seurat, L.G. 1904. Sur le rôle des algues vertes dans l'évolution des jeunes *Pinctada margaritifera*. Bull. Mus. Nat. Hist. Nat. Paris 10: 359-383.

- Shiber, J.G. 1980. Trace metals with seasonal considerations in coastal algae and mollusks from Beirut, Lebanon. *Hydrobiologia* 69(1-2): 147-162.
- Shiino, S.M. 1952. Anatomy of *Pteria (Pinctada) martensii* (Dunker), mother of pearl mussel. Spec. Publ. Fish. Experimental Station Mie Prefecture. 25 p.
- Shipley, A.E. and J. Hornell. 1904. Parasites of the pearl oyster, p. 77-107. In W.A. Herdman (ed.) Report to the Government of Ceylon on the pearl oyster fisheries of the Gulf of Manaar. Part II. The Royal Society of London.
- Shirai, S. 1970. The story of pearls. Japan Publications Inc., Japan. 132 p.
- Simpson, J.G. and R.C. Griffiths. 1967. The fishery resources of Venezuela and their exploitation. *Seri recursos y explotación pesqueros*. Venezuela 1(5): 191-206.
- Sims, N.A. 1990. The black-lip pearl oyster, *Pinctada margaritifera*, in the Cook Islands. University of New South Wales, Kensington, Australia, 109 p. MSc. thesis.
- Springsteen, F.J. and F.M. Leobrera. 1986. Shells of the Philippines. Carfel Seashell Museum, Manila.
- Suzuki, T. 1985. Comparative anatomy of the excretory organs and heart of bivalves subclasses Pterimorphia, Paleoheterodonta and Heterodonta. *Bull. Natl. Res. Inst. Aquacult. (Japan)/Yoshokukenhō* 7: 59-82.
- Talavera, F. and L. A. Faustino. 1931. Industrial shells of the Philippines. *Philipp. J. Sci.* 45: 321-350.
- Tanaka, H. 1990a. Winged pearl shell newly found in Tonga. *SPC Pearl Oyster Info. Bull.* 1: 15-15.
- Tanaka, H. 1990b. Japanese pearl imports: 1988 and 1989. *SPC Pearl Oyster Info. Bull.* 2: 8-8.
- Tanaka, Y. and S. Inoha. 1970. Studies on seed production of black-lip pearl oyster, *Pinctada margaritifera*, in Okinawa. IV. Resistibility of the larvae to centrifugally separated water from *Monochrysis* culture and to hypotonic sea water. *Bull. Tokai Reg. Fish. Res. Lab.* 63: 91-95.
- Tanaka, Y., S. Inoha and K. Kakazu. 1970a. Studies on seed production of blacklip pearl oyster *P. margaritifera* in Okinawa. I: Spawning induction by thermal stimulation. *Bull. Tokai Reg. Fish. Res. Lab.* 63: 75-78.
- Tanaka, Y., S. Inoha and K. Kakazu. 1970b. Studies on seed production of black-lip pearl oyster, *Pinctada margaritifera*, in Okinawa. II. Food micro-organisms available for the larvae. *Bull. Tokai Reg. Fish. Res. Lab.* 63: 79-85.
- Tanaka, Y., S. Inoha and K. Kakazu. 1970c. Studies on seed production of black-lip pearl oyster, *Pinctada margaritifera* in Okinawa. V. Rearing of the larvae. *Bull. Tokai Reg. Fish. Res. Lab.* 63: 97-106.
- Tanaka, Y., S. Inoha and S. Shokida. 1970d. Studies on seed production of black-lip pearl oyster, *Pinctada margaritifera*, in Okinawa. III. Culture experiment of *Monochrysis lutheri* at high water temperature levels. *Bull. Tokai Reg. Fish. Res. Lab.* 63:87-90.
- Tanaka, Y. and M. Kumeta. 1981. Successful artificial breeding of the silver-lip pearl oyster, *Pinctada maxima* (Jameson). *Bull. Natl. Res. Inst. Aquacult. (Japan)/Yoshokukenhō* 2: 21-28.
- Teshima, S., A. Kanazawa and R. Shimamoto. 1987. Akoyagai no suteroru oyobi shibosan sosei ni oyobusu shiryō sorui no eikyo. (Effects of algal diets on the sterol and fatty acid compositions of the pearl oyster *Pinctada fucata*). *Bull. Jap. Soc. Sci. Fish. (Nippon Suisan Gakkaishi)* 53(9): 1663-1667.
- Tranter, D.J. 1958a. Reproduction in Australian pearl oysters (Lamellibranchia). I. *Pinctada albina* (Lamarck): primary gonad development. *Aust. J. Mar. Freshwat. Res.* 9(1): 135-143.
- Tranter, D.J. 1958b. Reproduction in Australian pearl oysters (Lamellibranchia). II. *Pinctada albina* (Lamarck): gametogenesis. *Aust. J. Mar. Freshwat. Res.* 9(1): 144-158.
- Tranter, D.J. 1958c. Reproduction in Australian pearl oysters (Lamellibranchia). III. *Pinctada albina* (Lamarck): breeding season and sexuality. *Aust. J. Mar. Freshwat. Res.* 9(1): 144-158.
- Tranter, D.J. 1958d. Reproduction in Australian pearl oysters (Lamellibranchia). IV. *Pinctada margaritifera* (L). *Aust. J. Mar. Freshwat. Res.* 9(4): 509-523.
- Tranter, D.J. 1959. Reproduction in Australian pearl oysters (Lamellibranchia). V. *Pinctada fucata* (Gould). *Aust. J. Mar. Freshwat. Res.* 10: 45-66.
- Tsuji, T. 1968a. Studies on the mechanism of shell and pearl-formation. X. The submicroscopic structure of the epithelial cells on the mantle of pearl oyster, *Pteria (Pinctada) martensii* (Dunker). *Rep. Fac. Fish. Pref. Univ. Mie* 6: 41-58.
- Tsuji, T. 1968b. Studies on the mechanism of shell- and pearl-formation. XI. The submicroscopical observations on the mechanism of formation of abnormal pearls and abnormal shell. *Rep. Fac. Fish. Pref. Univ. Mie.* 6: 59-66.
- Uchimura, Y., A. Komaru, K.T. Wada, H. Ieyama, M. Yamaki and H. Furuta. 1989. Detection of induced triploidy at different ages for larvae of the Japanese pearl oyster, *Pinctada fucata martensii*, by microfluorometry with DAPI staining. *Aquaculture* 76(1-2): 1-9.
- Uemoto, H. 1961. Physiological studies on the nuclear insertion operation of pearl oyster. I-III. *Bull. Natl. Pearl Res. Lab.* 6: 619-635.
- Uwate, K., P. Kunatuba, B. Raobati and C. Tenakanai. 1984. A review of aquaculture activities in the Pacific Islands region. Pacific Islands Development Programme, East-West Center, Honolulu. 538 p.
- Vakily, J.M. 1989. The biology and culture of mussels of the genus *Perna*. *ICLARM Stud. Rev.* 17, 63 p.
- Vassel, E. 1896. Sur la pintadine du Golfe de Gabès. *Assoc. Farn. Av. Sci. Congr. de Cathage* 1896(2): 458-466.
- Velayudhan, T.S. 1983. On the occurrence of shell boring polychaetes and sponges on pearl oyster *Pinctada fucata* and control of boring organisms. Symposium on Coastal Aquaculture, 12-18 January 1980. Part 2. Molluscan culture. *Symp. Ser. Mar. Biol. Assoc. India* 6: 614-618.
- Velayudhan, T.S. 1987. Prospects of selective breeding of pearl oysters in India, p. 87-89. In K. Alagarwami (ed.) Pearl culture. *Bull. Cent. Mar. Fish. Res. Inst. No. 39*. Central Marine Fisheries Research Institute, Cochin, India.
- Velayudhan, T.S. and A.D. Gandhi. 1987. Morphology and anatomy of Indian pearl oyster, p. 4-12. In K. Alagarwami (ed.) Pearl culture. *Bull. Cent. Mar. Fish. Res. Inst. No. 39*. Central Marine Fisheries Research Institute, Cochin, India.
- Victor, A.C.C., A. Chellam and S. Dharmaraj. 1987. Pearl oyster spat collection, p. 49-53. In K. Alagarwami (ed.) Pearl culture. *Bull. Cent. Mar. Fish. Res. Inst. No. 39*. Central Marine Fisheries Research Institute, Cochin, India.
- Vokes, H.E. and E.H. Vokes 1983. Distribution of shallow-water marine mollusca, Yucatan Peninsula, Mexico. Mesoamerican Ecology Institute. Monograph 1: Middle America Research Institute. Publication 54. Tulane University, New Orleans.
- Volkman, J.K. 1989. Lipids of mariculture feedstocks and their role in animal nutrition, p. 22-23. In C.D. Garland and S.W. Jeffrey. Programme of the Third FIRTA-funded Micro-algae for Mariculture Workshop. University of Tasmania, Hobart.
- Wada, K. 1961. Crystal growth of molluscan shells. *Bull. Natl. Pearl Res. Lab.* 7: 703-828.

- Wada, K. 1962. Biomineralogical studies on the mechanism of pearl formation. Bull. Natl. Pearl Res. Lab. 8: 948-1059.
- Wada, 1968. Mechanism of growth of nacre in bivalvia. Bull. Natl. Pearl Res. Lab. 13: 1561-1596.
- Wada, K.T. 1973. Growth of Japanese pearl oyster larvae fed with three species of micro-algae. Bull. Natl. Pearl Res. Lab. 17: 2075-2083.
- Wada, K.T. 1976a. Number and gross morphology of chromosomes in the pearl oyster, *Pinctada fucata* (Gould), collected from two regions in Japan. Venus (Jap. J. Malacol.) Kaizatsu 35(1): 9-14.
- Wada, K.T. 1976b. Temperature requirement for maturation of gonads in Japanese pearl oysters. Bull. Nat. Pearl Res. Lab. 20: 2244-2253.
- Wada, K.T. 1978. Chromosome karyotypes of three bivalves: the oyster, *Isognomon alatus* and *Pinctada imbricata*, and the bay scallop, *Argopecten irradians irradians*. Biol. Bull. Mar. Biol. Lab. Woods Hole 155(1): 235-245.
- Wada, K.T. 1982. Interspecific and intraspecific electrophoretic variation in three species of the pearl oysters from the Nansei islands of Japan. Bull. Natl. Res. Inst. Aquacult. (Japan)/Yoshokukenho 3: 1-10.
- Wada, K.T. 1983. White coloration of the prismatic layer in inbred Japanese pearl oyster, *Pinctada fucata*. Bull. Natl. Res. Inst. Aquacult. (Japan)/Yoshokukenho 4: 131-133.
- Wada, K.T. 1984. Breeding study of the pearl oyster, *Pinctada fucata*. Bull. Natl. Res. Inst. Aquacult. (Japan)/Yoshokukenho. 6: 79-157.
- Wada, K.T. 1985. The pearls produced from the groups of pearl oysters selected for color of nacre in shell for two generations. Bull. Natl. Res. Inst. Aquacult. (Japan)/Yoshokukenho. 7: 1-7.
- Wada, K.T. 1986a. Genetic variability at four polymorphic loci in Japanese pearl oysters, *Pinctada fucata martensii*. Bull. Natl. Res. Inst. Aquacult. (Japan)/Yoshokukenho 9: 1-6.
- Wada, K.T. 1986b. Color and weight of shells in the selected populations of the Japanese pearl oyster *Pinctada fucata martensii*. Bull. Natl. Res. Inst. Aquacult. (Japan)/Yoshokukenho 9: 1-6.
- Wada, K.T. 1986c. Genetic selection for shell traits in the Japanese pearl oyster, *Pinctada fucata martensii*, selected for six generations. Aquaculture 57: 171-176.
- Wada, K.T. 1987. Selective breeding and intraspecific hybridization - molluscs, p. 313-322. In K. Tiews (ed.) Proceedings of the World Symposium on Selection Breeding and Genetic Engineering in Aquaculture, Bordeaux, France.
- Wada, K.T. 1989. Heritability estimation of larval shell length of Japanese pearl oyster. Bull. Natl. Res. Inst. Aquacult. (Japan)/Yoshokukenho 16: 83-88.
- Wada, K.T. and K. Komaru. 1985. Karyotypes in five species of the Pteriidae (Bivalvia: Pteriomorpha). Venus (Jap. J. Malacol./Kaizatsu 44(3): 183-192.
- Wada, K.T. and A. Komaru. 1990. Inheritance of white coloration of the prismatic layer of shells in the Japanese pearl oyster *Pinctada fucata martensii* and its importance in the pearl culture industry. Bull. Jap. Soc. Sci. Fish. (Nippon Suisan Gakkaishi) 90(56): 1787-1790.
- Wada, K.T. and A. Komaru. 1991. Gametogenesis of triploid bivalves with respect to aquaculture. Proceedings of the 18th U.S.-Japanese Meeting on Aquaculture. NOAA Tech. Rep. 106: 1-3.
- Wada, K. and A. Suga. 1977. Studies on the state of minor elements and the mineralization patterns of various cultured pearls by means of electron micro probe analysis, micro radiography and color television display. Bull. Natl. Pearl Res. Lab. 21: 2277-2298.
- Wada, K.T., A. Komaru and Y. Uchimura. 1989. Triploid production in the Japanese pearl oyster, *Pinctada fucata martensii*. Aquaculture 76(1-2): 11-19.
- Wada, S. 1942. Artificial fertilization and development in the silverlip pearl oyster *Pinctada maxima* (Jameson). Science in the South Seas 4: 202-208.
- Wada, S. 1947. Artificial fertilization of the Japanese pearl oyster in ammoniacal sea water. Bull. Jap. Soc. Sci. Fish. (Nippon Suisan Gakkaishi) 13(2): 59 p.
- Wada, S. 1953a. Biology of the silver-lip pearl oyster, *Pinctada maxima* (Jameson). I. Artificial fertilization and development. Margarita 1: 1-15.
- Wada, S. 1953b. Biology and fisheries of the silver-lip pearl oyster. Division of Fisheries and Oceanography, CSIRO, New South Wales. 86 p.
- Ward, F. 1985. The pearl. Nat. Geogr. 188(2): 193-222.
- Watabe, N. 1952. Relation between water temperature and nacre secreting activity of pearl oyster, *Pinctada martensii*. J. Fuji Pearl Inst. 2(4): 21-26.
- Wolf, P.H. and V. Sprague. 1978. An unidentified protistan parasite of the pearl oyster *Pinctada maxima*, in tropical Australia. J. Invertebr. Pathol. 31(2): 262-263.
- Yamaguchi, H. 1987. Sterols of the pearl-oyster. Bull. Jap. Soc. Sci. Fish. (Nippon Suisan Gakkaishi) 53(3): 497-501.
- Yamaguchi, K. 1959. Studies on the technique so-called 'Atozuke' (on the methods of nuclear insertion rarely used in pearl culture). I. Comparison between the 'Atozuke' and the common method in regard to the quality of produced cultured pearls. Bull. Natl. Pearl Res. Lab. 5: 499-502.
- Yamaguchi, K. 1961. Studies on the technique so-called 'Atozuke' (one of the methods of nuclear insertion in pearl culture). II. The relation between degrees of artificial spawning and pearl sac formation. Bull. Natl. Pearl Res. Lab. 6: 636-641.
- Yamaguchi, K. 1964. Studies on the technique so-called 'Atozuke' (one of the methods of nuclear insertion in pearl culture). IV. On the period from nuclear insertion to mantle piece insertion. Bull. Natl. Pearl Res. Lab. 9: 1128-1134.
- Yamashita, S. 1986. The Torres Strait pearling industry, p. 118-119. In A.K. Haines, G.C. Williams and C. Coates (eds.) Torres Straits Fisheries Seminar. Port Moresby. February 1985. Australian Government Publishing Service, Canberra.
- Yi, S.K. 1987. Study for the development of pearl culturing techniques (III). Korea Ocean Research and Development Institute Advanced Institute of Science and Technology.
- Yonge, C.M. 1960. Oysters. Willmer Bros. & Harman, London. 209 p.
- Yoo, S.K., Y.J. Chang and H.S. Lim. 1986. Growth comparison of pearl oyster, *Pinctada fucata* between the two culturing areas. Bull. Korea Fish. Soc. 19(6): 593-598.
- Yuki, R. and S. Kobayashi. 1950. On breeding of pearl oyster in tank. Studies on pearl. J. Fuji Pearl Inst. 1: 7-8; 2: 10-16.



#### TITLES OF RELATED INTEREST

**A bibliography of the pearl oysters (Bivalvia: Pteriidae).** M. Gervis. 1991. *ICLARM Bibliogr.* 11, 99 p. Available on diskette, together with the software Paperbase. US\$10.00 including airmail delivery.

**The biology and culture of marine bivalve molluscs of the genus *Anadara*.** M.J. Broom. 1985. *ICLARM Stud. Rev.* 12, 37 p. US\$3 surface, \$6 airmail, P45.

**The biology and culture of tropical oysters.** C.L. Angell. 1986. *ICLARM Stud. Rev.* 13, 42 p. US\$3 surface, \$6 airmail, P50.

**The biology and culture of mussels of the genus *Perna*.** J.M. Vakily. 1989. *ICLARM Stud. Rev.* 17, 63 p. US\$3.50 surface, \$5.50 airmail, P65.

**The biology and culture of pearl oysters (Bivalvia: Pteriidae).** M.H. Gervis and N.A. Sims. 1992. *ICLARM Stud. Rev.* 21, 49 p. US\$3 surface, \$5 airmail, P70.

#### HOW TO ORDER

Enquirers from the USA should order directly from our exclusive distributor - **International Specialized Book Services**, 5602 N.E. Hassalo St., Portland, Oregon 97213-3640, to whom payment should be directed using the *airmail* price. Persons in Canada and Central and South America may also find ISBS a convenient source.

Enquirers from Europe may order from **S. Toeche-Mittler GmbH**, Versandbuchhandlung, Hindenburgstrasse 33, D-6100 Darmstadt, Federal Republic of Germany using the *airmail* price.

Enquirers elsewhere should address orders and payment (payable to ICLARM) in US\$ by international money order, bankdraft or UNESCO coupons to: The Editor, ICLARM, MC P.O. Box 1501, Makati, Metro Manila, Philippines. We can accept US\$ checks only if from a US-based bank due to high clearance fees of other banks. Write for a free catalogue of all ICLARM publications.